

# Linear guidance system Speedi-Roll

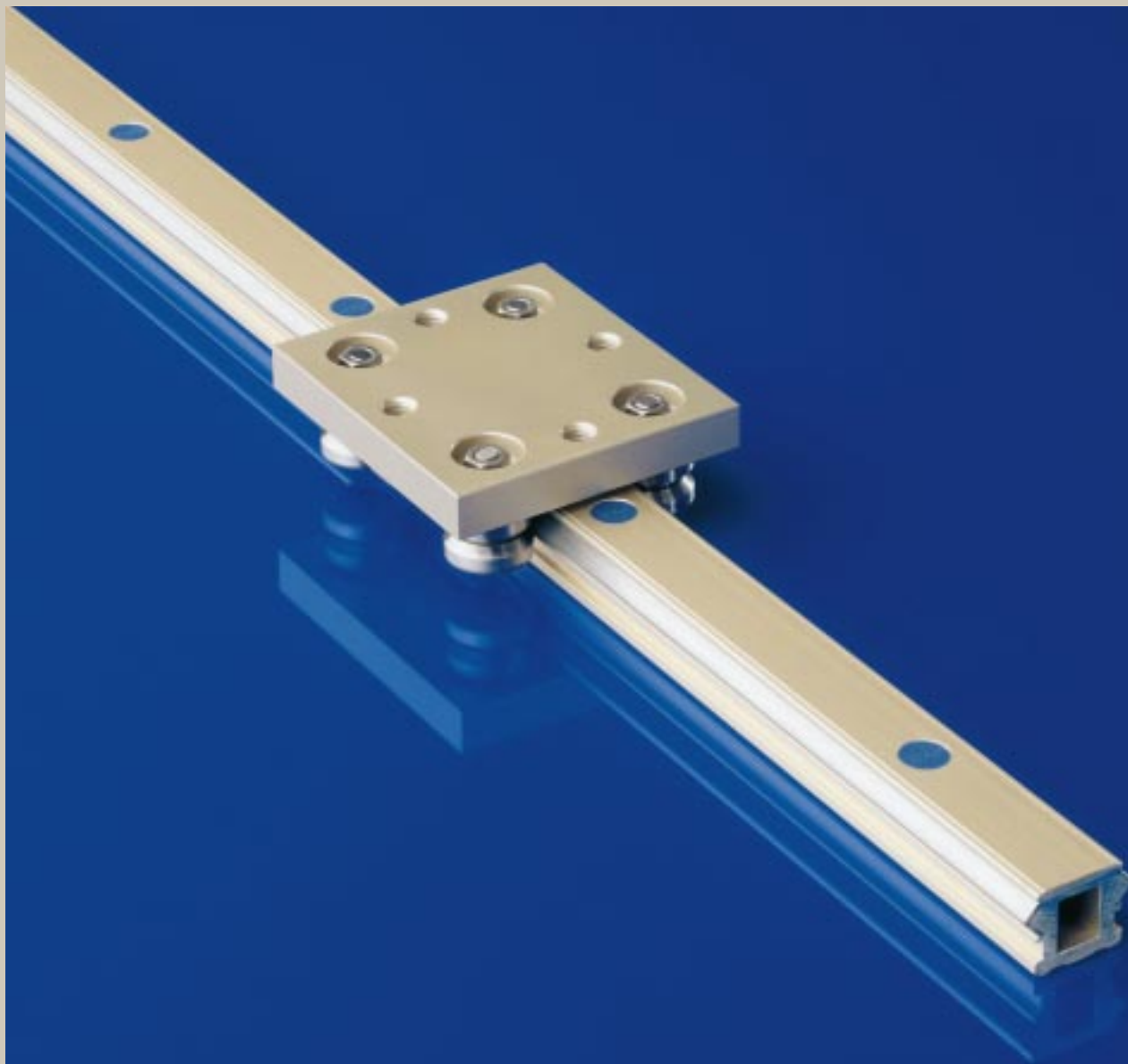

## The SKF Group

The SKF Group is an international industrial corporation of AB SKF Sweden, founded in 1907, operating in 130 countries. The company has some 45000 employees and more than 80 manufacturing facilities throughout the world. Its international network is supported up by nearly 20000 distributors and retailers. SKF is the world leader in the rolling bearing business. Bearings, seals and special steels are SKF's main product areas. In addition, they also manufacture and sell, other industrial precision components and products.

## SKF Linear Motion

One of these industrial precision products assortment is manufactured and sold by the SKF Linear Motion Division. This unit has some 700 employees, 6 manufacturing facilities, 3 product lines. One of the division's strengths is its ability to serve the market through its organization based on 11 specialized Sales Companies located in Europe and North America; however product availability and product application support is provided world-wide by the SKF international network.

## CD-ROM "Designer"

All linear Motion products are available in this CD, in DWG and DXF files. Thanks to "Designer", you can easily copy the drawing of the product you need into your own design drawing. If you are interested, please do not hesitate to contact your local SKF sales organization. It is free of charge.

The Linear Motion product range covers:

- High Efficiency Screws
- Linear Guiding Systems
- Electromechanical Actuators

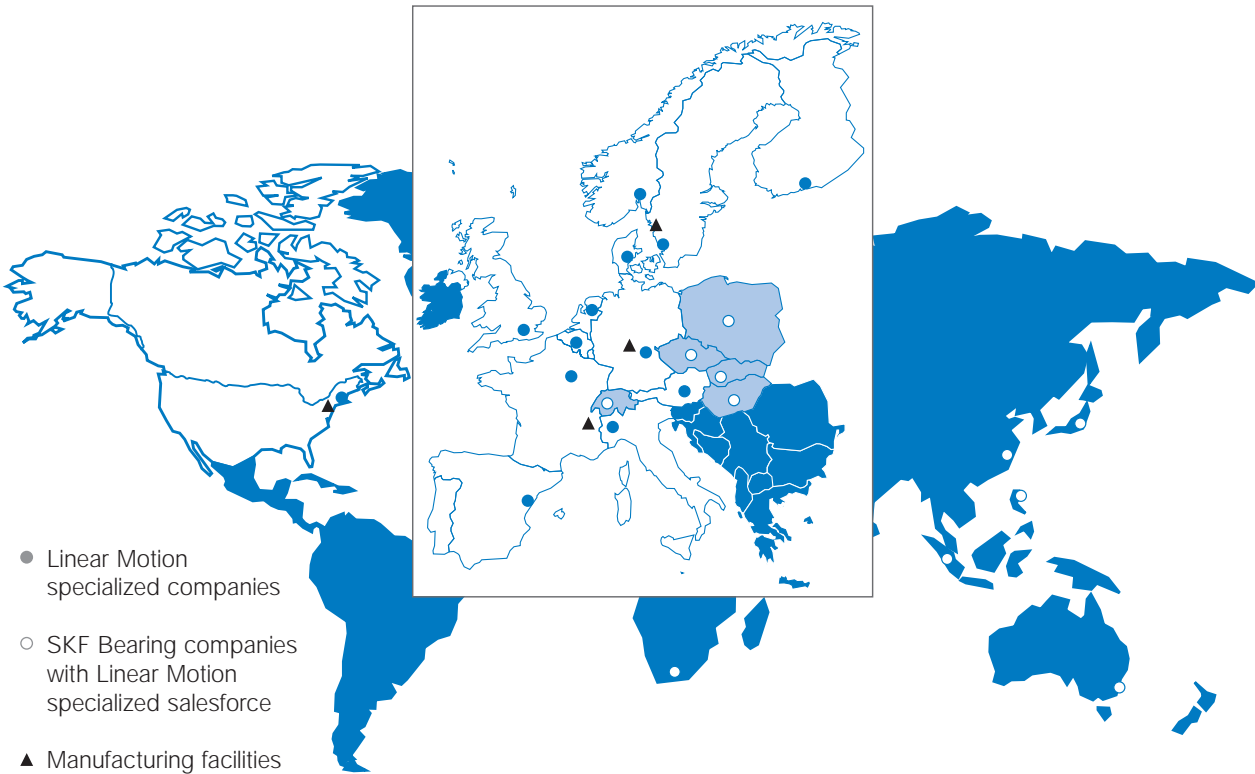

Catalogue n° 9311 E / VII  
47173 · 1000 · 2000-03

Printed in Germany  
by Weppert GmbH & Co. KG

© Copyright SKF 1994  
The contents of this catalogue are the copyright of the publishers and may not be reproduced (even extracts) unless permission is granted. Every care has been taken to ensure the accuracy of the information contained in this catalogue but no liability can be accepted for any errors or omissions.

Earlier catalogues the data in which deviate from those given here, are rendered invalid. The right is reserved to make changes necessitated by technological developments.

**Product Overview** 3

**Accuracy** 4

**Application** 4

**Installation instructions** 5

**Lubrication** 6

**Calculation** 6

**Stiffness** 8

**Calculation example** 8

**Designation system** 9

**Dimensions** 10

**Accessories** 12

## Product overview

To complement its versatile range of linear motion products, SKF has introduced the LLE linear guidance system, a highly efficient unit marketed under the name „Speedi-Roll“. In response to current market demands this product was developed giving high priority to lightweight construction and ease of installation.

Speedi-Roll is a linear guide system with high load carrying capacity, rigidity and torque resistance, consisting of a guide rail and a carriage with either four or six rollers. The rail is composed of a drawn and anodized aluminium body with hardened steel angle raceways fitted on each side. The aluminium base plate of the carriage, which is also anodized, houses the factory-fitted rollers. A special feature of this roller design is the presence of elastic elements around the threaded bolt with which

the rollers are adjusted and fixed in the base plate. This unique, patented system avoids the risk of mounting error and thus contributes significantly to a more efficient and cost effective installation.

The units are supplied as standard with a light preload and, in order to cover a wide range of applications, SKF offers three sizes: LLE 15, 25 and 35. This allows for flexibility when selecting a system to meet design parameters. Speedi-Roll guides operate effortlessly and quietly. The high linear speed rating permits shorter cycle times and the low friction between the rollers and rail means less power is required to drive the system. The hollow centres in the sizes 25 and 35 rails provide a reduction in mass of the total system and can also be used as channels to carry such things as wires or cables. The rollers are lubricated-for-life, greatly reducing the need for service.

To round-out the programme roller covers and end stops are also available.

In addition to the catalogue range, it is possible, using the standard roller and steel angle raceways, to produce special configurations. Please consult SKF for details.

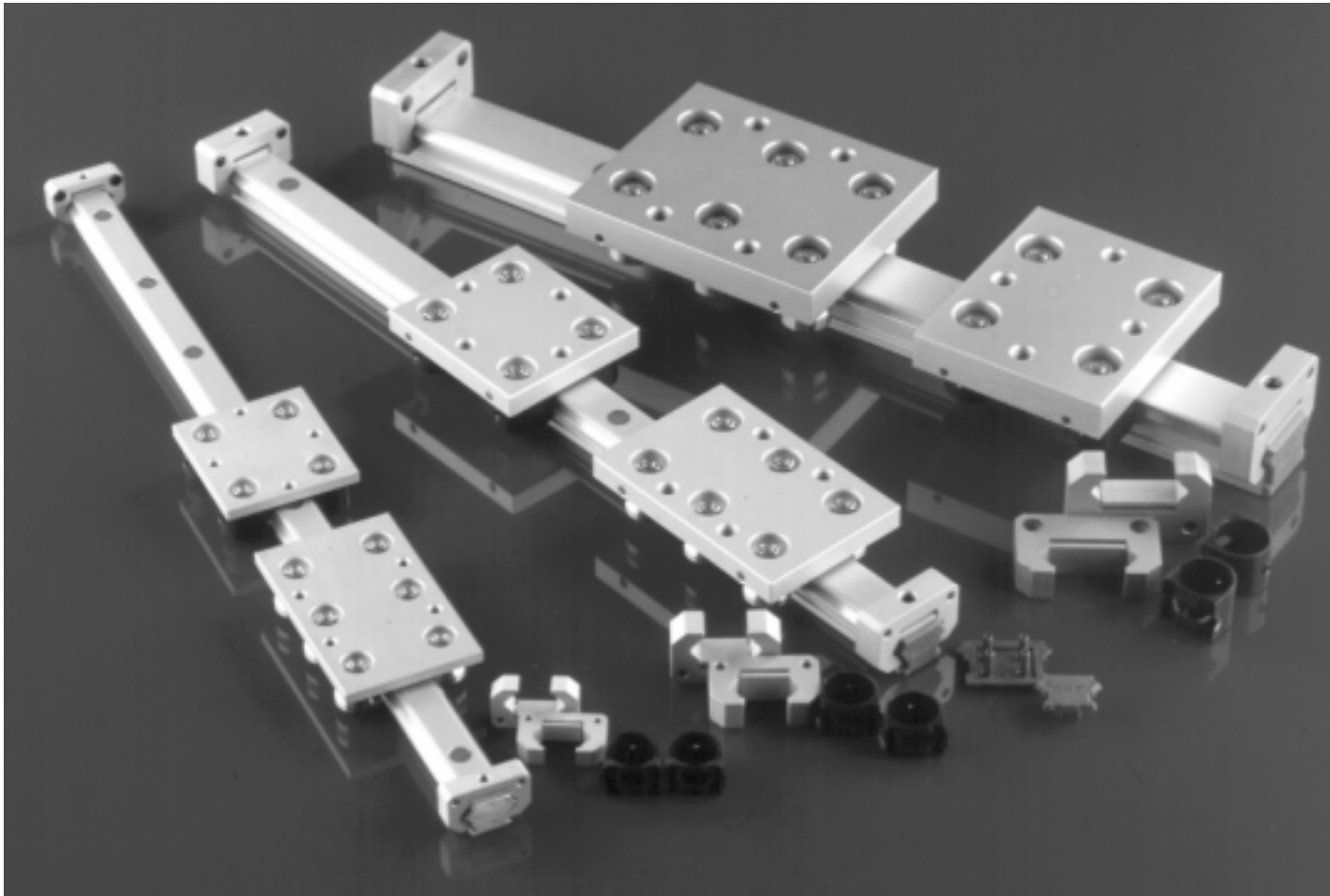

## Accuracy

The system is offered with a straightness of 0,05 mm/m in the horizontal and vertical planes. Systems with higher degrees of accuracy are obtainable on request.

Fig. 1  
For the measurement of accuracy the rail is supported at the ends by gauge blocks. The accuracy is measured over one metre.

- 1) Vertical parallelism of the system (vertical deviation between the centre of the carriage surface and the centre of the underside of the rail over one metre travel).
- 2) Horizontal parallelism of the system (lateral deviation between the centre of the carriage surface and the side of the rail over one metre travel).

## Application

The characteristics and features of this system make it suitable for a wide variety of applications.

Basic specifications:

Speed of travel	up to 10 m/s;
Straightness	0,05 mm/1 m
Load Capacity	see tables provided
Travel	unlimited
Rail length	max. 4000 mm, larger lengths may be assembled from more than one rail
Temperature range	-20° to 80°C under constant conditions

Typical applications for Speedi-Roll include:

- Packaging machines
- Material handling systems
- Tool changers
- Robotics
- Woodworking machines
- Textile machines
- Medical engineering
- Leisure industry

SKF engineers are always available to discuss special applications.

Fig. 1

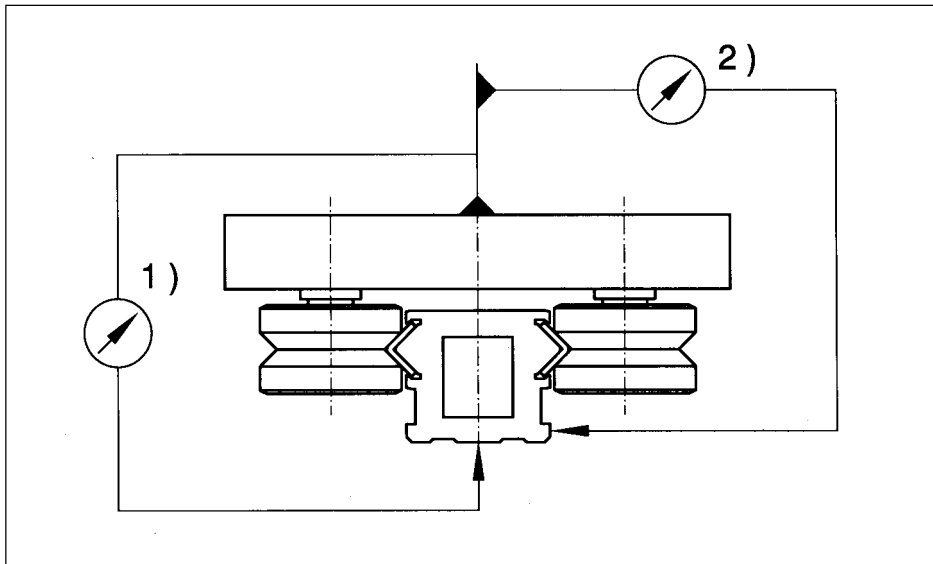

# Installation instructions

The guide rail and carriage elements are precision products which must be handled with care. Installation should be carried out in a suitably clean environment.

The carriages are factory-mounted and adjusted on the guide rails, thus eliminating the need for any subsequent adjustment on site.

Prior to installation the mating surfaces should be cleaned and any remaining burrs removed. Dimensional accuracy of all adjacent components should be verified as being of an equal standard to that of Speedi-Roll itself.

Removal of the guide from the packing should not take place until immediately before installation. The guide rail should be carefully placed upon the machine bed and secured by loosely fastening the attachment screws.

The guide rails can then be aligned or pressed against an abutment and the screws finally tightened. They should be aligned using suitable measuring equipment, taking the first mounted guide as a reference.

The permissible tightening torque for the screws can be obtained from Table 1a.

Mating parts should only be fastened to the Speedi-Roll system after it has been aligned and secured. See table 1a for allowable tightening torques for fastening to the carriage base plate.

If the carriage is removed from the guide rail, great care must be taken to avoid any tilting during refitting.

After complete checking of the linear axes, the screw tops in the guide rail may be concealed by the caps provided as part of the system.

**Table 1a**  
Maximum permissible tightening torque for attachment screws <sup>1)</sup>

	Rail Nm	Carriage Nm
LLEHS 15	6	2,5
LLEHS 25	10	10
LLEHS 35	22	20

<sup>1)</sup> These values apply to quality grade 8.8 screws.

**Table 1b**  
Locknuts Set screws

System	M <sub>A</sub> [Nm]	M <sub>B</sub> [Nm]
LLEHS 15	8	-
LLEHS 25	9	0,6
LLEHS 35	18	1,25

# Fitting of track rollers

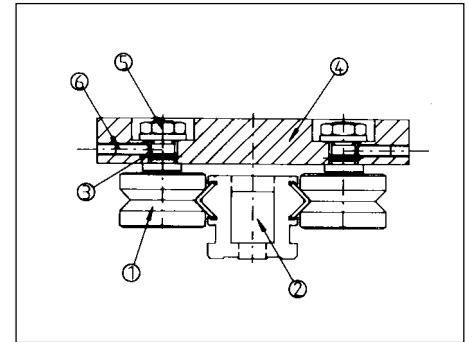

When mounting the rollers in a baseplate the following instructions should be followed:

1. Insert the threaded bolts of the track roller ① through the mounting hole ③ in the carriage plate ④.
2. Fit the support washer and locknut ⑤ onto the track roller thread and lightly tighten. The track roller should be restrained from axial but allow for radial movement.
3. Mount the carriage on the guide rail ② and check that it runs smoothly throughout the stroke. Make sure the rollers all run without clearance.
4. Tighten the locknut ⑤, and set screw ⑥ for sizes 25 and 35, to about 50% of the fixing torques specified in table 1. To avoid twisting of the carriage tighten both track rollers on the same side of the guide rail before tightening the remaining track rollers. An adjustment of the carriage can be made by applying radial pressure inwards or outwards during tightening. This will compress the O-rings ③ adjusting the fit of the carriage assembly.
5. Check that the carriage still runs smoothly and clearance free. Then fully tighten both track rollers on the same side of the guide rail before tightening the remaining track rollers. If the carriage does not run smoothly, release the locknuts and set screws and repeat starting from point 4.
6. Finally, tighten the set screws (for sizes 25 and 35) to the full torque given in table 1b.

# Lubrication

Adequate lubrication of all components is essential in obtaining full performance of the Speedi-Roll-System.

The rollers themselves are lubricated for life and require no maintenance. The raceways are preserved and protected but must be greased before the unit is put into operation. Medium viscosity grease should be used. Mineral oil based SKF greases such as LGMT 3, LGEP 2 and LGEM2 are suitable for virtually all application conditions.

It will be necessary to regrease the rails after a period of time, depending on operating parameters such as temperature and the grades of grease used. Detailed instructions may be obtained from the SKF "Linear Guide Handbook", Catalogue 4185 E, Page 30.

# Calculation

The calculation of the forces acting within the Speedi-Roll assembly is complicated by the combination of radial bearing type forces and linear motion principles. The following section has therefore been simplified to allow for a more general understanding and calculation of the effects of applied loads.

The  $L_{10}$  life of the Speedi-Roll has been derived from basic bearing principles using a nominal life of 100 000 meters. The load capacity or the non-bearing components of the carriage and rail assembly are however the practical limiting factors to be taken into account when specifying a Speedi-Roll solution. See dimension table 5, page 10.

The nominal life expectancy of the rolling elements is calculated and the bearing system as a whole is analysed in terms of its static bearing capacity (as a measure of protection against overload). Use is made of the general equation (1) for the calculation of the life:

$$(1) L_{10} = \left(\frac{C}{P}\right)^3$$

where

- $L_{10}$  nominal life,  $10^5$  m
- C dynamic load rating of the carriage, N
- P equivalent dynamic load on the carriage, N

Here, C represents the bearing load at which a life of 100 km travel is obtained. P is the constant magnitude in a given direction for the highest loaded carriage, thus determining the service life of the linear motion system.

Radial bearing principles are not the limiting factor in the Speedi-Roll assembly. The flexibility of the top plate and roller stub axles become the limiting factor in any application. These limiting loads are defined on page 11 and must not be exceeded.

$P = F$  may be selected if constant load conditions as defined apply during operation. In all other cases P has to be determined as an equivalent vector. Calculation guidelines for such variable load assumptions are given in the SKF

"Linear Guide Handbook", Page 52 et seq.

If precise knowledge of all operating conditions is available, equation (2) for the modified service life should be applied:

$$(2) L_{10_s} = \left(\frac{C \cdot f_l}{P \cdot f_d}\right)^3$$

where

- $L_{10_s}$  modified nominal life,  $10^5$  m
- $f_l$  coefficient for the influence of load direction
- $f_d$  coefficient for load conditions

At a constant stroke length and stroke frequency, the life can also be simply expressed in hours of operation: (3)

$$(3) L_{10_h} = \frac{5 \cdot 10^7}{s \cdot n \cdot 60} \cdot \left(\frac{C \cdot f_l}{P \cdot f_d}\right)^3$$

where

- $L_{10_h}$  modified nominal life time working hours
- s stroke, mm
- n frequency of stroke,  $\text{min}^{-1}$  (number of movements from one end position to the other end and back again)

Note: The dynamic load ratings (see table 3) are defined as the load which gives a bearing life of 100 000 m. It is assumed that the load is constant in magnitude and direction and acts perpendicularly to the plane of travel of the unit and that the stroke is at least one third of the total slide length. These loads must not be used as the maximum permissible system loads.

A system may be subjected to simultaneous horizontal and vertical loads. The maximum permissible loads that may be applied are defined in the tables. These apply to loads acting through the centre of the carriage and along its main axis.

In the case of complex loads, all component loads must be determined in order of direction, summarized and compared with the permissible system loads.

Depending on the roller, variable load angles can be generated by the axial and radial force components. Their influence on the service life is expressed by the coefficient for the influence of the load direction  $f_l$ . The value for  $f_l$  can be obtained from Diagram 1. The load acting on the carriage is the resultant of various static and dynamic components. Vibration, shock loads, etc. may be allowed for using the coefficient  $f_d$  for load conditions, see Table 2.

The static safety factor is expressed by the general equation (4):

$$(4) s_o = \frac{C_o}{P_o} \cdot f_l$$

- $s_o$  static safety factor
- $C_o$  static load rating of the carriage, N
- $P_o$  equivalent static load on the carriage, N
- $f_l$  coefficient for the influence of load direction

Under normal operations  $s_o$  should be greater than 1. Values must not fall below 3 to 5 if shock loads are anticipated. Coefficient  $f_l$  should be used for correction, depending on the load angle.

Diagram 1

Coefficient  $f_l$  for the influence of load direction

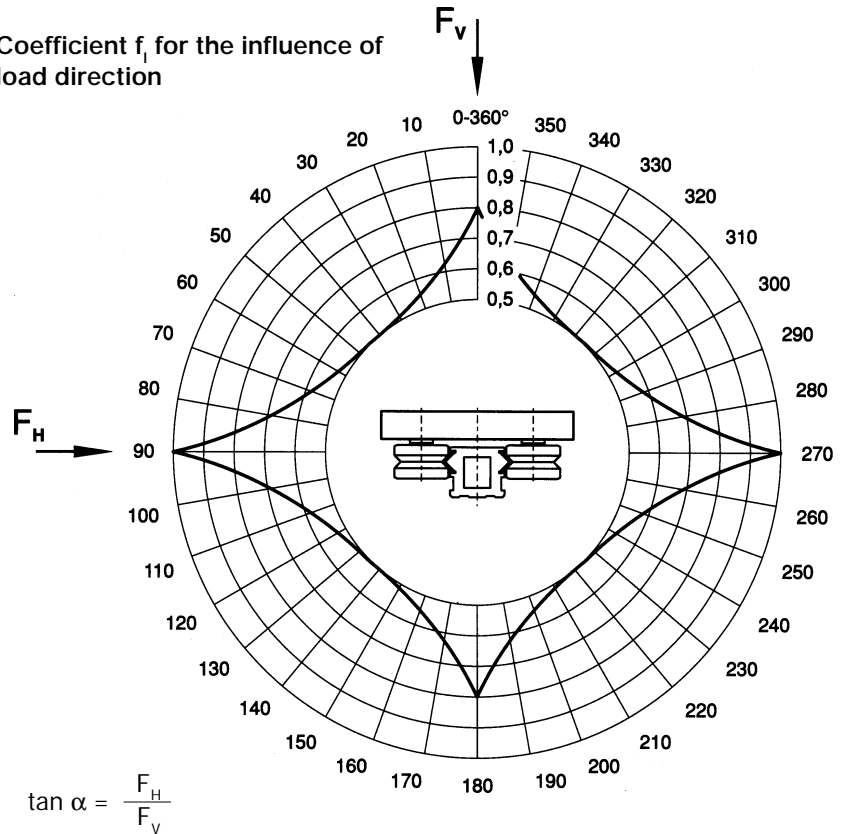

Table 2

Coefficient  $f_d$  for load conditions

Load conditions	$f_d$
	from to
Smooth operation without shock load	1,0 – 1,2
Low shock loads	1,2 – 1,5
High shock loads	1,5 – 3,0

Table 3

Basic Load Rating

	C N	$C_o$ <sup>4)</sup> N
LLEHS 15	2000	1200
LLEHS 15L	2600	1800
LLEHE 15	2850	1400
LLEHS 25	4000	2700
LLEHS 25L	5200	4000
LLEHE 25	2850	1400
LLEHS 35	6000	4250
LLEHS 35L	8000	6350
LLEHE 35	4400	2200

<sup>4)</sup> Data for radial direction, load angle 90° or 270°, with load centrally applied to the carriage.

When a torque load is applied to the carriage, the equivalent force must be determined, and the life calculated as follows:

$$F = \frac{M_l}{l}$$

l Carriage Data,  $W_3$ ,  $L_3$

Limiting values for permissible torque are defined in the dimension table on page 10.

Note:

To prevent excessive mounting stresses, the spacing between two carriages should be at least 3 times the carriage length  $L_1$ .

The influence of the stroke length has been ignored in the above calculations. Please consult SKF if the stroke is less than the carriage length.



# Rigidity

All sizes of Speedi-Roll, when used within the permissible loads, give adequate rigidity. Where guide rails are not fully supported and have to serve as load-bearing members, the flexing can be calculated according to the equations of elastic curves. The moment of inertia may be obtained from Table 4.

**Table 4**  
Moment of Inertia of LLEHR Guide Rails

	$I_y$ mm <sup>4</sup>	$I_z$ mm <sup>4</sup>	$e_z$ mm
LLEHR 15	7350	10030	8,8
LLEHR 25	16000	22000	11,0
LLEHR 35	69000	100200	14,9

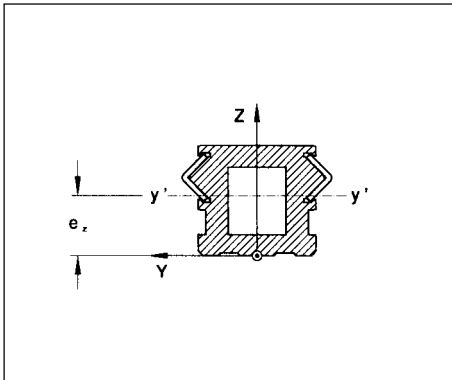

# Calculation Example

A linear table is to be made up of two Speedi-Roll, size 25, rail guide assemblies. The length of travel is 1500mm, and the stroke frequency is 5 min<sup>-1</sup>. The centrally applied load is constant in magnitude and direction (see illustration).

The load is 1400 N and is expected to be moved smoothly without any shocks.

The life of the linear table, in km and hours of operation, as well as the static safety factor of the system is required.

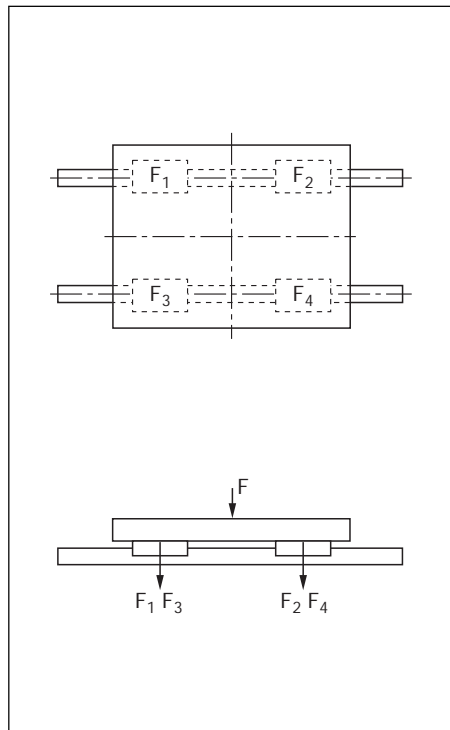

The equivalent dynamic load on a carriage is:

$$P = \frac{F}{4} = \frac{1400}{4} = 350 \text{ N}$$

The lifetime in km is calculated to be:

$$L_{10_s} = \left( \frac{C \cdot f_l}{P \cdot f_d} \right)^3 = \left( \frac{4000 \cdot 0,8}{350 \cdot 2} \right)^3 = 9550 \text{ km}$$

$f_l$  and  $f_d$  are taken from Diagram 1 and Table 2 on page 7.

In operating hours:

$$\begin{aligned} L_{10_h} &= \frac{5 \cdot 10^7}{s \cdot n \cdot 60} \cdot \left( \frac{C \cdot f_l}{P \cdot f_d} \right)^3 = \\ &= \frac{5 \cdot 10^7}{1500 (5) (60)} \cdot \left( \frac{4000 \cdot 0,8}{350 \cdot 2,0} \right)^3 = \\ &= 10600 \text{ hours} \end{aligned}$$

The static safety factor is calculated as follows:

$$S_o = \frac{C_o}{P_o} \cdot f_l$$

$$S_o = \frac{2700}{350} \cdot 0,8$$

$$S_o = 6,2$$

With this value it can be safely assumed that there will be no deformation in the system during operation.

# Designation system

The following designation system should be used when ordering Speedi-Roll

**LLE H S 15 H Z 2 - 300 / A**

- Special design  
A = joined rail  
D = guide rails as specified  
M1 = system with one endstop  
M2 = system with two end stops.  
H = hard chrome coated
- Length of guide rail in mm
- Number of carriages per guide rail
- Sealing  
Z = Without roller covers  
C = With roller cover
- Carriage type  
H = Standard (4 rollers)  
L = Long (6 rollers)
- Size (15, 25, 35)
- System key  
S = guide rail and carriage (system)  
C = carriage  
R = guide rail  
E = roller  
X = roller cover  
M = Endstop
- guide rail type  
H
- Prefix for Speedi-Roll

**Designation Examples:**

Roller cover: LLEHX 25

End stop: LLEHM 15

2 long carriages size 25 with roller covers + 0,5 m rail + 2 endstops: LLEHS 25 LC 2 - 500 M2

# Dimensions

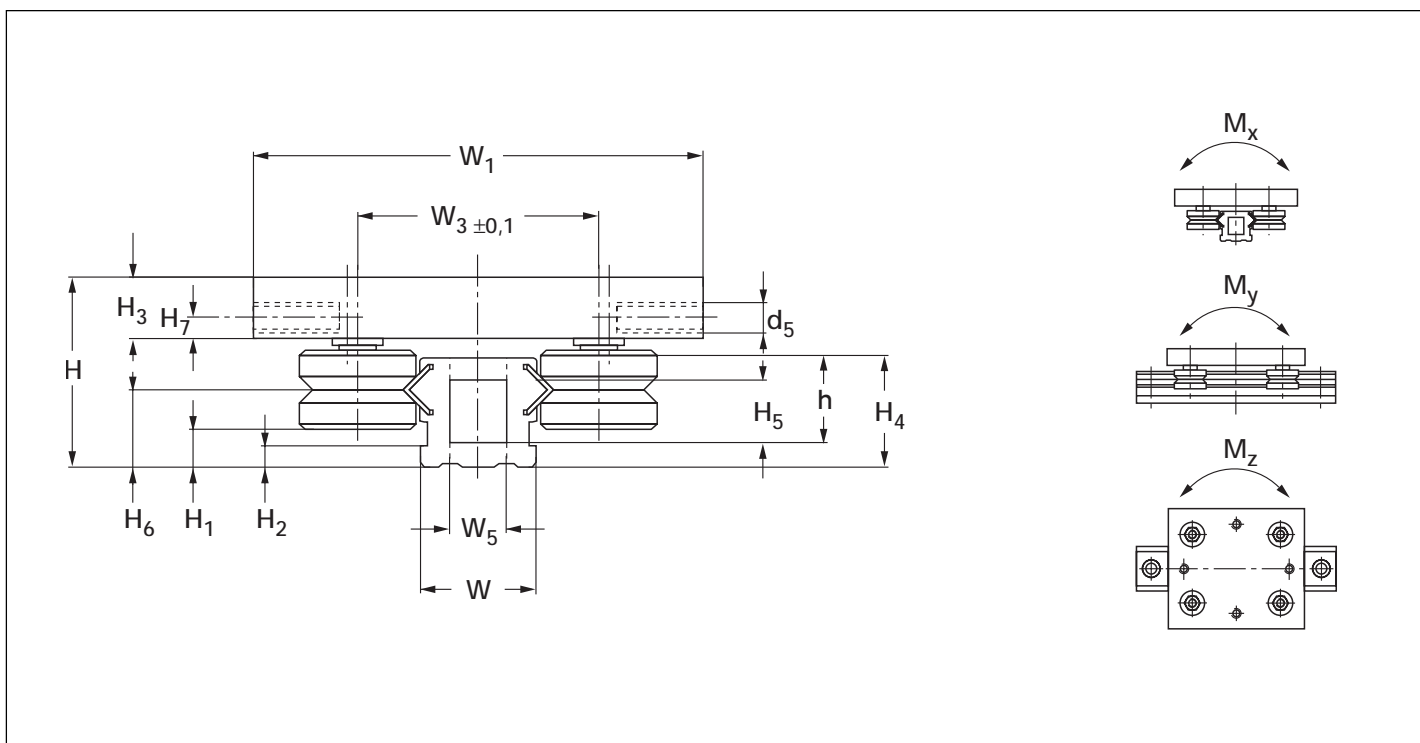
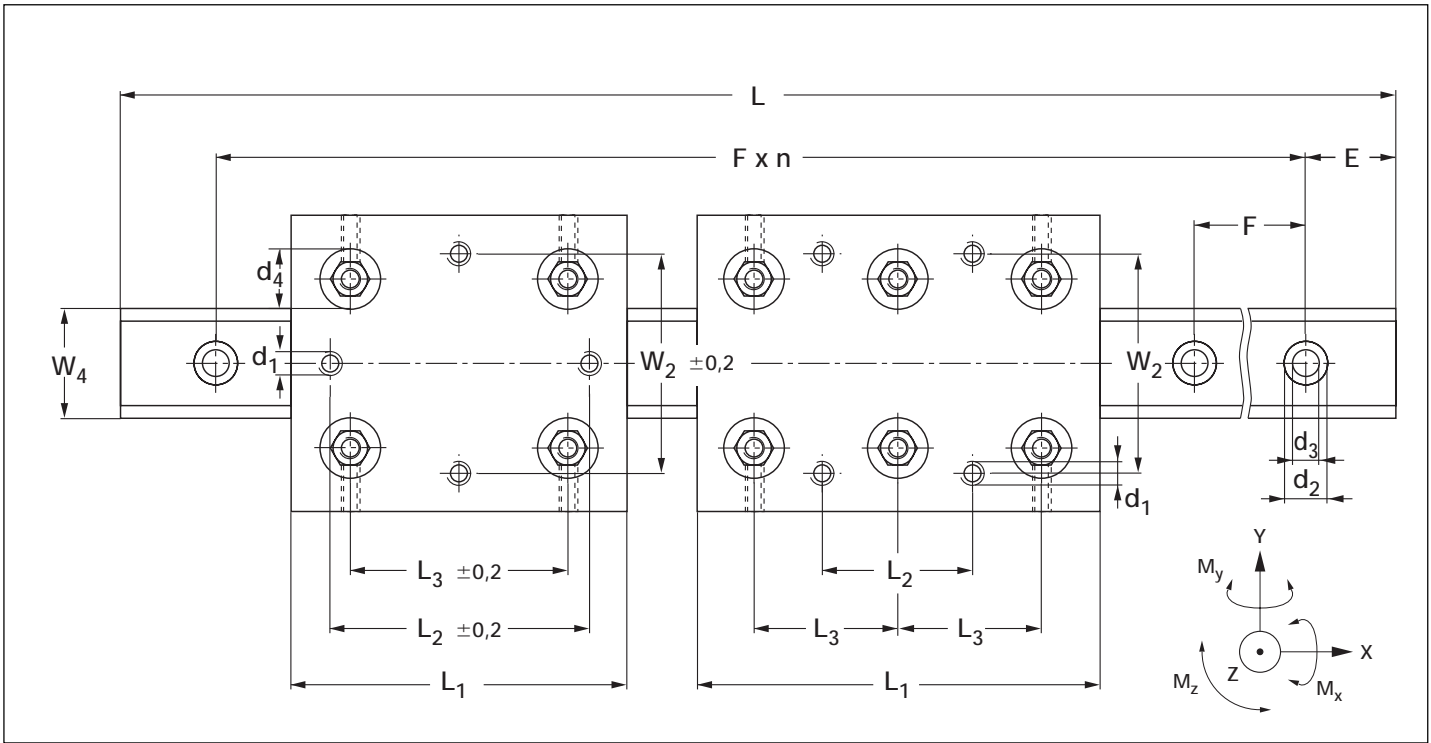

Table 5

Size	Dimensions			Carriage										Rail			
	System			$L_1$	$W_2$	$L_2$	$W_3$	$L_3$	$H_3$	$d_1$	$d_4$	$H_7$	$d_5$	$W$	$W_4$	$H_2$	$H_4$
	$H$	$H_1$	$W_1$														
mm			mm										mm				
LLEHS 15	25,0	3,75	65	70	50	60	39,3	45	6,05	M5	14	-	-	18	24,9	2	17
LLEHS 15L	25,0	3,75	65	105	50	35	39,3	35	6,05	M5	14	-	-				
LLEHS 25	35,5	7,7	80	90	59	70	45,8	60	12,1	M8	17	3,7	M4	23	29,9	4	21
LLEHS 25L	35,5	7,7	80	120	59	40	45,8	40	11,8	M8	17	3,7	M4				
LLEHS 35	54,3	12,35	120	100	90	70	61,3	65	19,4	M10	21	4,5	M4	36	42,9	7	29
LLEHS 35L	54,3	12,35	120	140	90	50	61,3	50	19,4	M10	21	4,5	M4				



										Permissible Load					Weight	
$W_5$	$H_5$	$H_6$	$d_2$	$d_3$	$h$	$F$	$E$	$L$		$F_{y \text{ perm.}}$	$F_{z \text{ perm.}}$	$M_{x \text{ perm.}}$	$M_{y \text{ perm.}}$	$M_{z \text{ perm.}}$	Rail	Carriage
										N	1)	Nm			kg/m	kg
-	-	10,75	9,5	5,5	8,5	62,5	31,25	6000		700	660	10	12	6	0,9	0,2
										1000	900	18	21	12		0,3
11	13	14,7	11,0	6,5	17	125	62,5	6000		1000	1400	28	38	13	1,0	0,4
										1500	2000	45	53	20		0,5
20	15	22,75	20,0	11,0	22	250	125	6000		2500	2500	70	76	35	2,0	0,9
										3200	3200	97	106	52		1,3

1) Data for centrally acting loads. In the case of eccentrically acting loads the values should be corrected according to the laws of mechanics. In the case of dynamic loads acting in the z-direction  $F_z$  should be multiplied by a factor of 0,6.

## Roller covers

In addition to protecting each roller from surrounding contaminants, roller covers (designated LLEHX 15, 25, 35) act as wipers on the rail raceway and thus help keep it free from dirt.

Due to their integrated functions and simple design the roller covers help reduce costs. The covers hold themselves in position over the rollers and do not require any additional fastening, and a funnel-type lubrication hole is provided for regreasing.

Another advantage is the increased contact pressure of the roller cover lip which results from the fluid friction of the grease between the rotating track roller and the stationary cover. This ensures the wiping effect even at high speeds.

## End stops

The end stops (designation LLEHM 15, 25, 35) can be locked in any position on the guide rail. As safety devices, they can act as emergency stops for the system in case of a failure in the electronic control, or in manual operation prevent overshoot of the carrier. They are also reliable carriage locking devices for the transportation and handling of the guide system. The design of the anodized aluminium end stops is in line with that of the entire system and integral plastic stops are present to provide further damping.

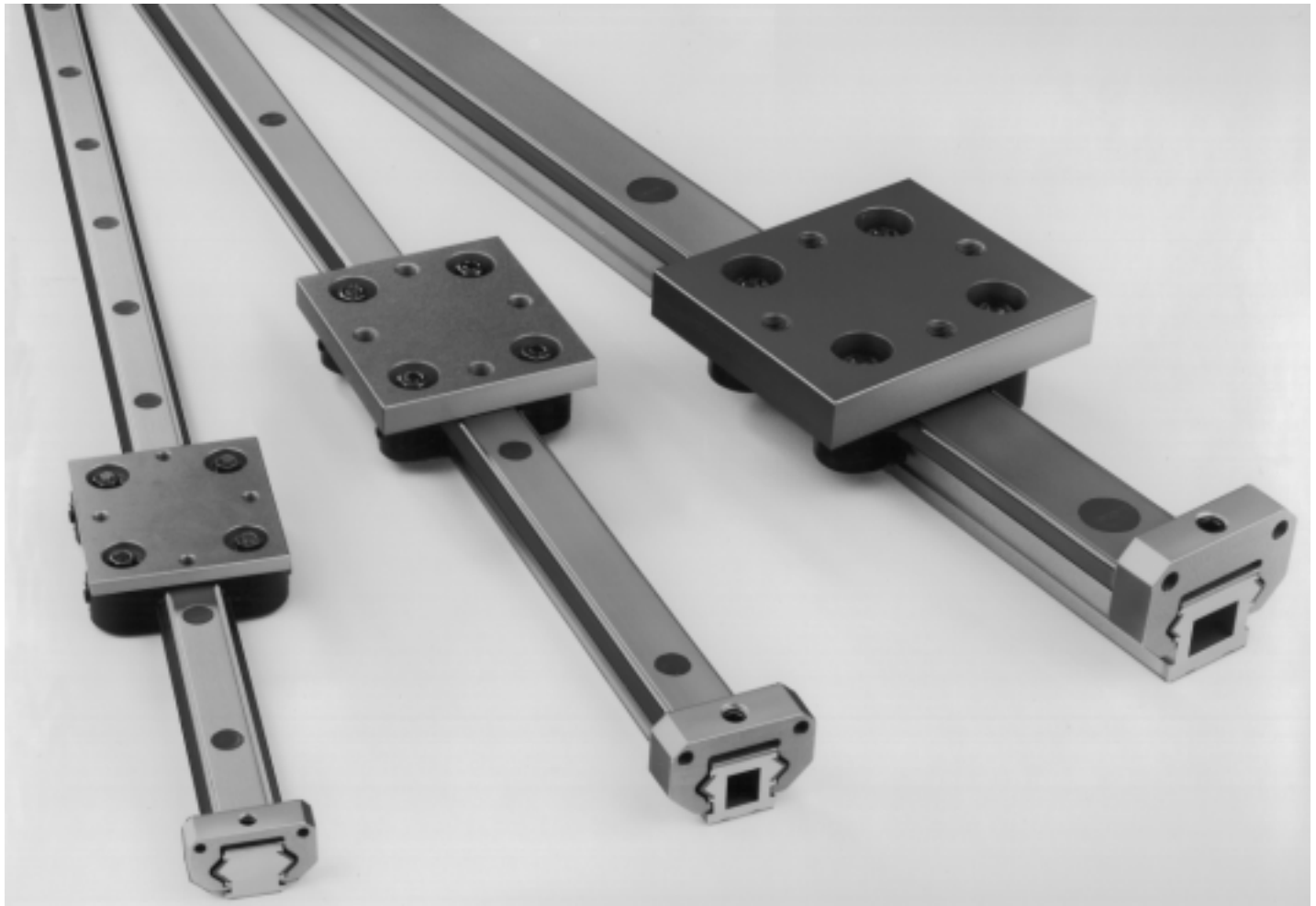

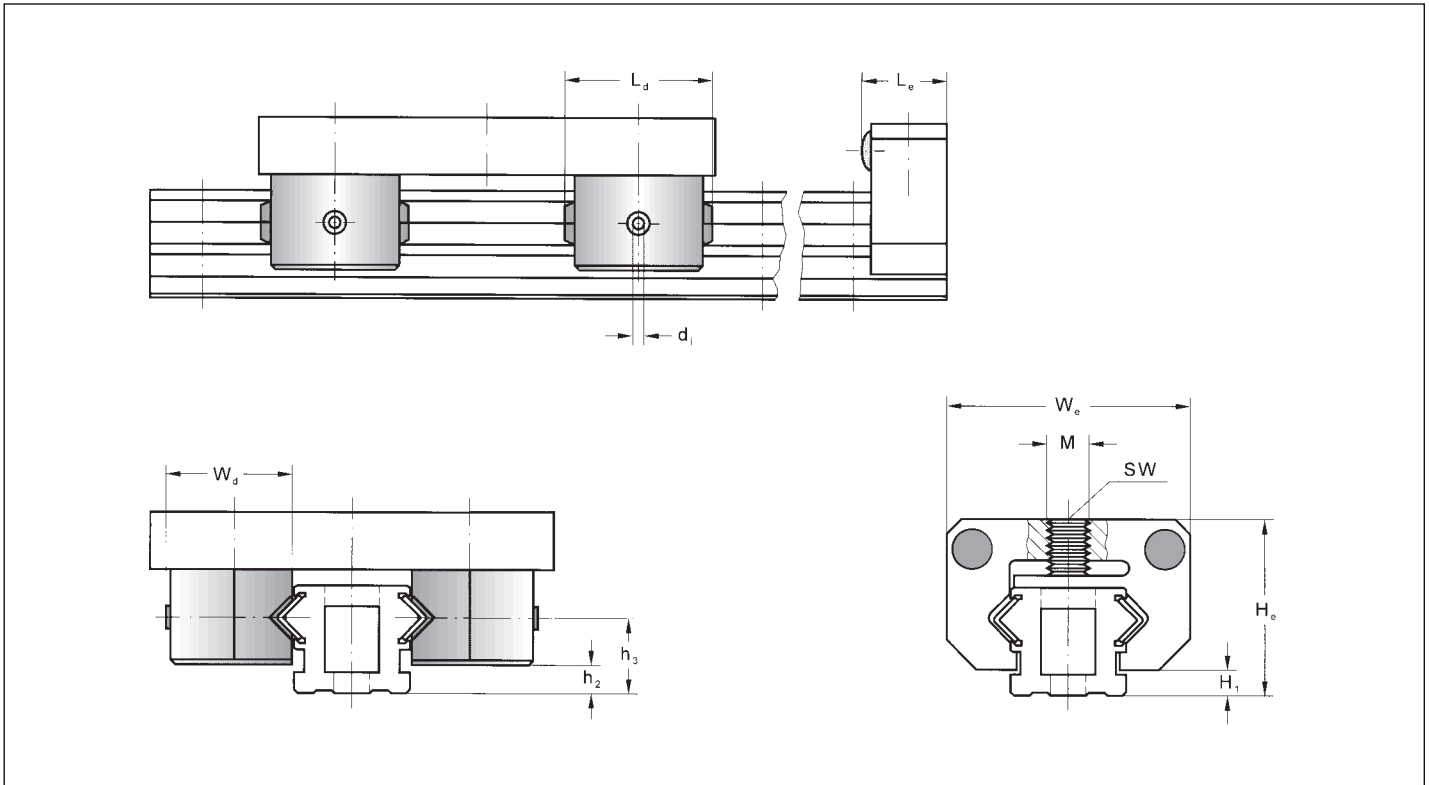

### Endstops

### Roller covers

Size	$H_e$	$H_1$	$W_e$	$L_e$	M	SW	Size	$L_d$	$W_d$	$h_2$	$h_3$	$d_i$
LLEHM 15	24,5	2,5	38	11,1	M5	2,5	LLEHX 15	29,2	23,6	1,65	10,75	2
LLEHM 25	34,1	4,6	48	16,6	M8	4	LLEHX 25	29,2	25,1	5,6	14,7	2
LLEHM 35	52	12	65	16,6	M10	5	LLEHX 35	31,8	27,8	10,95	22,75	2

# SKF Sales companies

## Australia

SKF AUSTRALIA PTY. LTD  
P. O. Box 301  
OAKLEIGH, Victoria 3166  
Phone: + 61 (3) 5 67 28 00  
Fax: + 61 (3) 5 67 28 88

## Austria

SKF ÖSTERREICH AG  
IKANO Bürogebäude  
Postfach 87  
A-2355 WIENER NEUDORF  
Phone: + 43 (22 36) 6 70 90  
Fax: + 43 (22 36) 6 70 92 20

## Benelux

SKF MULTITEC BENELUX B. V.  
Kelvinbaan 16  
NL-3439 MT Nieuwegein  
Phone: + 31 306 029 029  
Fax: + 31 306 029 028  
Phone: (B) + 32 2 5024270  
Fax: (B) + 32 2 5027336

## Canada

SKF CANADA LIMITED  
40 Executive Court  
SCARBOROUGH, ONTARIO  
MIS 4 N 4  
Phone: + 1 (4 16) 2 99 12 20  
Fax: + 1 (4 16) 2 92 03 99

## Czech Republic

SKF LOŽISKA A.S.  
P. O. Box 19  
U Měštánského pivovaru 7  
17004 PRAHA 7  
Phone: + 420 (0)2 66 19 71 11  
Fax: + 420 (0)2 66 71 04 15

## Denmark

SKF MULTITEC  
Bramdrupskovvej 17  
DK-6000 KOLDING  
Phone: + 45 - 75 52 95 77  
Phone: + 46 - 42 25 35 00  
Fax: + 45 - 75 52 95 66

## Finland

SKF MULTITEC  
PL 60  
FIN-02201 ESPOO  
Phone: + 3 58 94 52 97 54  
Fax: + 3 58 94 27 76 5

## France

SKF EQUIPEMENTS  
30/32 Ave. Des Trois Peuples  
B. P. 83  
F-78185 SAINT QUENTIN  
Yvelines Cedex  
Phone: + 33 (1) 30 64 28 28  
Fax: + 33 (1) 30 64 41 31

## Germany

SKF LINEARSYSTEME GMBH  
Verkauf Deutschland  
Hans-Böckler-Straße 6  
97424 SCHWEINFURT  
Phone: + 49 (97 21) 6 57 - 0  
Fax: + 49 (97 21) 6 57 - 111

## Great Britain

SKF ENGINEERING PRODUCTS LTD.  
Sundon Park Road  
Luton  
BEDFORDSHIRE LU3 3BL  
Phone: + 44 (15 82) 49 0049  
Fax: + 44 (15 82) 49 6574

## Hong Kong

SKF CHINA LIMITED  
Unit A 35/F. Manulife Tower  
169 Electric Road · North Point  
HONG KONG  
Phone: + 852 - 25 10 81 11  
Fax: + 852 - 25 10 73 68

## Hungary

SKF SVĚD GOLYÓSCSAPÁGY  
RESZVENYTARSASAG  
Csata u. 25  
HU-2040 BUDAÖRS  
Phone: + 36 (23) 41 59 96  
Fax: + 36 (23) 41 59 28

## Italy

SKF MULTITEC S.p. A.  
Corso Vittorio Emanuele II, 94  
I-10121 TORINO  
Phone: + 39 (011) 57 17 61  
Fax: + 39 (011) 5 71 76 33

## Norway

SKF MULTITEC A/S  
Jerikoveien 14  
1067 OSLO  
Postal address: Postboks 7  
Lindeberg Gård  
N-1007 OSLO 10  
Phone: + 47 (2) 2 30 71 70  
Fax: + 47 (2) 2 30 28 14

## Poland

SKF CENTRALA HANLOWO-  
TECHNICZNA SP. ZO.O.  
ul. Pulawska 303  
02-785 WARSZAWA  
Phone: + 48 22 549 4700  
Fax: + 48 22 549 4701

## Portugal

SKF PORTUGAL · Rolamentos Lda.  
Casal de Alfragide, Lote 1,  
AMADORA  
Postal address: Apartado 60141,  
P-2700 AMADORA  
Phone: + 35 (1) 4 17 36 36  
Fax: + 35 (1) 4 17 36 49 (general)  
4 17 36 50 (sales)

## Sweden

SKF MULTITEC AB  
Ekslingan 3  
HELSINGBORG  
Postal address: Box 222 48  
S-25024 HELSINGBORG  
Phone: + 46 (42) 25 35 00  
Fax: + 46 (42) 25 35 45, 25 35 46

## Singapore

SKF SOUTH EAST ASIA &  
PACIFIC PTE. LTD.  
153 Gul Circle Jurong  
Singapore 629610  
Postal Address:  
Jurong Point P. O. Box 445  
SINGAPORE 916415  
Phone: + 65 - 8 61 69 22  
Fax: + 65 - 8 61 10 11

## Spain

SKF PRODUCTOS INDUSTRIALES S.A.  
Apartado 769  
E-08080 BARCELONA  
Phone: + 34 (93) 3 77 99 77  
Fax: + 34 (93) 4 74 20 39/31 56

## Switzerland

SKF (SCHWEIZ)  
Eschenstraße 5  
CH-8603 SCHWERZENBACH  
Phone: + 41 (1) 8 25 81 81  
Fax: + 41 (1) 8 25 82 82

## USA

SKF MOTION TECHNOLOGIES  
1530 Valley Center Parkway  
USA-BETHLEHEM, PA 18017  
Phone: + 1 (610) 861 - 4800  
Fax: + 1 (610) 861 - 4811



**SKF Guiding Systems**



**SKF Ball & Roller Screws**



**SKF Actuators**

SKF Linear Motion offers a wide range of precision engineered linear motion components, units and systems. In addition to comprehensive product literature and software, SKF offers assistance from experienced linear motion engineers.

Linear Motion has **3 product lines** and a sales organisation based on **11 specialized sales companies** located in Europe and in the USA.

However the product availability as well as the product application is **world-wide granted by the SKF Bearing international network**. To get any other SKF address all over the world, please contact one of the companies below.

### Austria

#### Linear Motion

SKF Österreich AG  
Phone: +43 22 36 6709-0  
Fax: +43 22 36 6709-220

### Benelux

#### SKF Multitec Benelux B.V.

Phone: +31 30 6029029  
Fax: +31 30 6029028

Sales Office Belgium/Luxembourg:

Phone: +32 2 5024270  
Fax: +32 2 5027336

### France

#### SKF Equipments

Phone: +33 1 30 64 28 28  
Fax: +33 1 30 64 41 31

### Germany

#### SKF Linearsysteme GmbH

Phone: +49 9721 657-0  
Fax: +49 9721 657-111

### Italy

#### SKF Multitec S.p. A.

Phone: +39 11 57 17 61  
Fax: +39 11 5 71 76 33

### Norway

#### SKF Multitec A/S

Phone: +47 22 30 71 70  
Fax: +47 22 30 28 14

### Spain

#### SKF Productos Industriales, S.A

Phone: +34 93 377 99 77  
+34 93 377 99 07  
Fax: +34 93 474 20 39/31 56

### Sweden/Denmark/Finland

#### SKF Multitec

Phone: +46 42 25 35 00  
Fax: +46 42 25 35 45/46

Sales Office Denmark

Phone: +45 75 51 95 77  
Fax: +45 75 51 95 66

Sales Office Finland

Phone: +358 94 52 97 52  
Fax: +358 942 77 65

### United Kingdom

#### SKF Engineering Products Ltd.

Phone: +44 1582 490049  
Fax: +44 1582 496574

### USA

#### SKF Motion Technologies

Phone: +1 610 861-4800  
Fax: +1 610 861-4811

<http://www.linearmotion.skf.com>

