

SKF

Composite dry sliding bearings - maintenance-free and space-saving

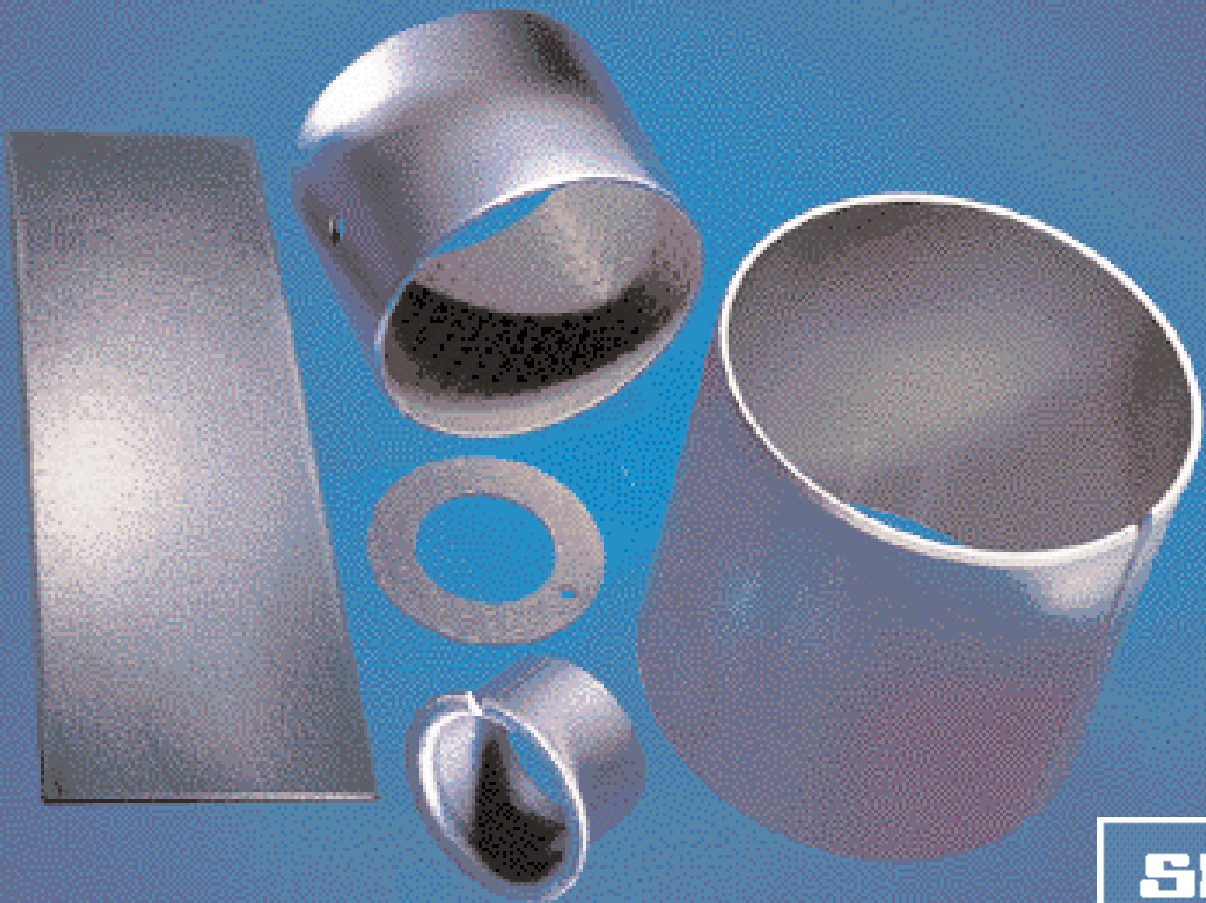

Contents

Maintenance-free and space-saving.....	3
Materials	6
Machinability of composite materials	8
Friction	8
Chemical properties.....	9
Selection of bearing size	10
Basic load ratings	10
Service life.....	11
Requisite bearing size.....	11
Calculation of service life	13
Application of bearings	14
Design of associated components	22
Seals	23
Lubrication.....	24
Mounting	25
Bearing data – general.....	26
Product tables	27
Composite bushings with metric dimensions.....	27
Composite bushings with inch dimensions	34
Composite flanged bushings	38
Composite thrust washers.....	39
Composite strip	40
Other related products	41
Application examples	44
The SKF Group – a worldwide corporation.....	54



Maintenance-free and space-saving

Dry sliding bearings of composite material are primarily used for bearing arrangements where heavy loads have to be supported but where rotational or oscillating movements are relatively slow. Because of their good sliding properties and compact design, these plain bearings are particularly suitable for bearing arrangements where

- freedom from maintenance is required,
- there is a risk of lubricant starvation, lubricants should not be used or are forbidden, or
- very limited space is available.

Typical application areas for SKF composite dry sliding bearings and examples will be found on **pages 44 to 52**.

Characteristics

The important characteristics of SKF composite dry sliding bearings include

- freedom from maintenance
- no lubrication required (PTFE composite)
- initial lubrication required (POM composite)
- minimum wall thickness, minimum space requirements
- can support heavy loads
- wide operating temperature range
- good sliding properties
- practically without stick-slip
- little wear
- insensitive to edge loads (POM composite)
- no machining required







The assortment

The standard range of SKF composite dry sliding bearings is very comprehensive and meets most needs for this type of product. The range is shown in the product overview (→ **Table 1**) and comprises

- bushings,
- flanged bushings,
- thrust washers, and
- strip.



Maintenance-free and space-saving

Bearing	Series	Bore diameter	Lubrication needed	Permissible temperature range
Plain bushings PTFE composite 	PCM .. B	3 – 300 mm	No	-200 to +250 °C
	PCZ .. B	0,125 – 7 inch	No	-200 to +250 °C
POM composite 	PCM .. M	8 – 300 mm	Yes, on mounting	-40 to +110 °C short periods +130 °C
	PCZ .. M	0,375 – 4 inch	Yes, on mounting	-40 to +110 °C short periods +130 °C
Flanged bushings PTFE composite 	PCMF .. B	6 – 35 mm	No	-200 to +250 °C
Thrust washers PTFE composite 	PCMW .. B	15 – 52 mm	No	-200 to +250 °C
	POM composite 	PCMW .. M	15 – 52 mm	Yes, on mounting
Strip PTFE composite 	PCMS .. B	500 × 100 mm Height 1 to 2,5 mm	No	-200 to +250 °C
	POM composite 	PCMS .. M	500 × 100 mm Height 1 to 2,5 mm	Yes, on mounting

Series	Characteristics	Page
PCM .. B	Dry sliding bushings with metric dimensions of triple-layer PTFE composite material (→ page 6). Suitable for slow rotational and oscillating movements under radial load and maintenance-free operation. No lubrication required.	27
PCZ .. B	Dry sliding bushings with inch dimensions of triple-layer PTFE composite material (→ page 6). Suitable for slow rotational and oscillating movements under radial load and maintenance-free operation. No lubrication required.	34
PCM .. M	Dry sliding bushings with metric dimensions of triple-layer POM composite material (→ page 6). Suitable for slow rotational and oscillating movements and also linear movements under radial load and maintenance-free operation but also where there is a risk of errors of alignment, edge loading or moderate contamination. Initial lubrication required.	27
PCZ .. M	Dry sliding bushings with inch dimensions of triple-layer POM composite material (→ page 6). Suitable for slow rotational and oscillating movements and also linear movements under radial load and maintenance-free operation but also where there is a risk of errors of alignment, edge loading or moderate contamination. Initial lubrication required.	34
PCMF .. B	Dry sliding bushings with flange on one side and metric dimensions of triple-layer PTFE composite material (→ page 6). Suitable for slow rotational and oscillating movements under radial and single direction axial loads. For maintenance-free operation. No lubrication required.	38
PCMW .. B	Dry sliding thrust washers with metric dimensions of triple-layer PTFE composite material (→ page 6). Suitable for space-saving arrangements for axial location. For slow rotational and oscillating movements under axial load and maintenance-free operation. No lubrication required.	39
PCMW .. M	Dry sliding thrust washers with metric dimensions of triple-layer POM composite material (→ page 6). Suitable for space-saving arrangements for axial location. For slow rotational and oscillating movements under axial load and maintenance-free operation and where there is a risk of edge loading or moderate contamination. Initial lubrication required.	39
PCMS .. B	Dry sliding strip of triple-layer PTFE composite material (→ page 6). The strip can be bent, pressed, cut etc. to fit the particular application. Suitable for space-saving, maintenance-free arrangements of all types. No lubrication required.	40
PCMS .. M	Dry sliding strip of triple-layer POM composite material (→ page 6). The strip can be bent, pressed, cut etc. to fit the particular application. Suitable for space-saving, maintenance-free arrangements of all types and where there is a risk of moderate contamination or edge loading. Initial lubrication required.	40

Materials

There are two standard types of composite material for SKF dry sliding bearings: PTFE composite and POM composite, which differ in their sliding layers. They are suitable in different bearing applications.

PTFE composite

The PTFE composite material has a copper-plated sheet steel backing on to which a 0,2 to 0,4 mm thick porous layer of tin bronze is sintered (→ fig 1). The pores of the sintered layer are filled with a mixture of PTFE (polytetrafluoroethylene) and lead by a rolling process. The sintered bronze layer is covered by a 5 to 30 µm thick running-in layer of the same mixture.

There is an optimum combination of the mechanical properties of the sintered bronze and the good sliding and lubricating properties of the PTFE mixture in PTFE composite bearings. It has good dimensional stability and thermal conductivity.

PTFE composite bearings are identified by designation suffix B, e.g. PCM 101212 B.

POM composite

The POM composite material also has a sheet steel backing which is copper plated, and also a 0,2 to 0,4 mm thick layer of sintered tin bronze (→ fig 2). The principal characteristic of these bearings is their relatively thick (0,3 mm) covering layer of acetal resin (POM – polyoxymethylene) which is firmly anchored in the sintered bronze layer. The covering layer has pockets to retain lubricating grease.

The thickness of the covering layer makes bearings insensitive to a certain degree of misalignment and the edge loading associated with misalignment.

POM composite bearings are identified by designation suffix M, e.g. PCM 101212 M.

PTFE composite dry sliding material

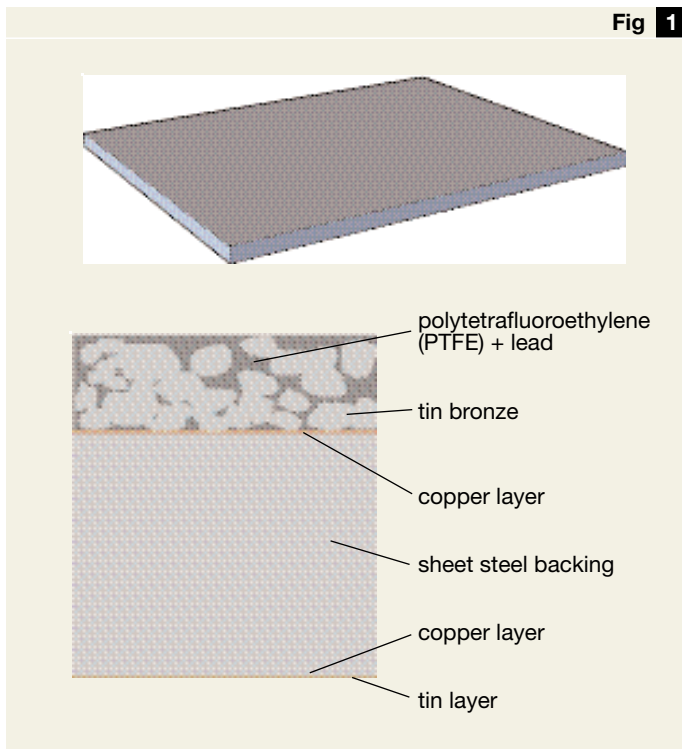

POM composite dry sliding material

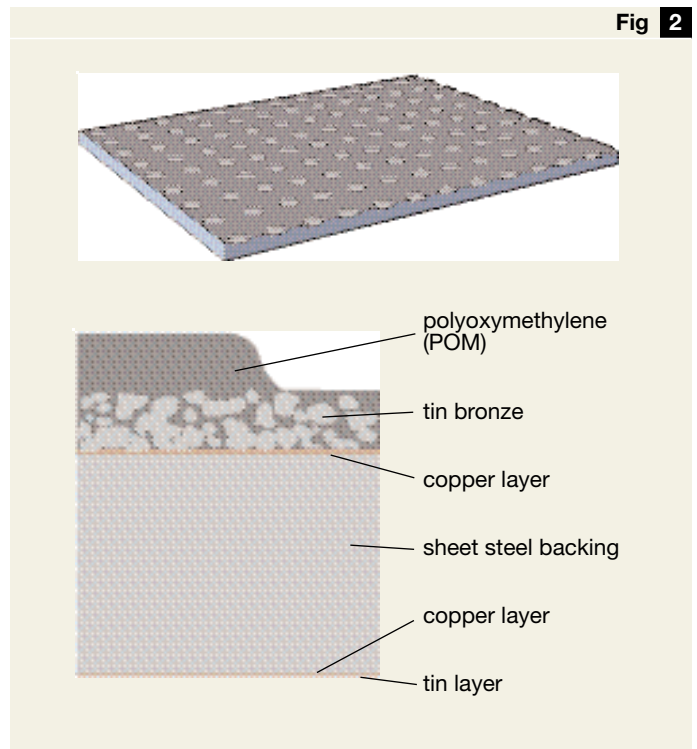

**Summary of characteristics of SKF
PTFE composite and POM composite
dry sliding materials**

Table 2

Characteristics	PTFE composite	POM composite
Composition	steel backing with sintered layer of tin bronze; pore filling and covering layer (5 to 30 µm) of PTFE with lead additives	steel backing with sintered layer of tin bronze; pore filling and covering layer (0,3 mm) of POM
Permissible specific static bearing load (N/mm ²)	250	250
Permissible specific dynamic load (N/mm ²)	80	120
Maximum sliding velocity (m/s)	2	2,5
Operating temperature range (°C)	-200 to +250	-40 to +110 (+130 for brief periods)
Coefficient of friction	0,03 to 0,25	0,02 to 0,20
Stick-slip effect	negligible	negligible
Wear layer thickness (mm)	0,2	0,3
Lubrication	not required	initial lubrication required
Ability to support edge loads (e.g. resulting from misalignment)	fair	good
Ability to carry alternating loads	good	fair
Ability to accommodate linear movement	fair	good
Machining of sliding surface after mouting	calibration	drilling, turning, (reaming)
Recommended housing tolerance for bushings	H7	H7
Recommended shaft tolerance for bushings	f7 (for d ≤ 75 mm) h8 (for d > 75 mm)	h8 h8
Required surface roughness of mating surface (µm)	R _z ≤ 3 R _a ≤ 0,4	R _z ≤ 6 R _a ≤ 0,8
Permissible surface machining of mating surface	ground (drawn)	drawn

Machinability of composite materials

SKF composite dry sliding bearing materials – with the exception of the sliding layer – can be machined using conventional methods.

If bushings are required to have a smaller width than the standard size, this can easily be achieved by turning or parting-off. It is also possible to drill lubrication holes. Care must be taken to see that any burrs are removed, particularly from the sliding surface.

Strip can be bent, coined, pressed, cut, bored or drilled to shape to fit the individual application. When cutting or drilling it is advisable to work from the sliding surface side to avoid creating burrs in the sliding layer.

Any bright metal surfaces produced as a result of machining should be given protection against corrosion.

PTFE composite bushings

These bushings are supplied in a ready-to-mount condition. Any subsequent machining of the bore, i.e. the sliding surface, should only be undertaken in exceptional cases as it will reduce the service life. If necessary, however, the bore should be calibrated using a mandrel (→ fig 3). If a PTFE

composite bushing having an outside diameter D is to be mounted in a steel housing having an outside diameter D_G , guideline values for the requisite diameter d_K of the calibrating mandrel ($= d + \Delta d_K$) will be found in **Diagram 1**. This diagram gives the requisite interference Δd_K of the calibrating mandrel as a function of the desired expansion Δd of the bushing bore for various nominal bushing bore diameters d . The diagram is valid for the ratio $D_G/D = 2$. No values are given for bushings installed in light alloy housings as the influence of design parameters and the housing material is too great. In such cases, the requisite diameter of the calibrating mandrel must be established by trials.

POM composite bushings

Bushings made of the POM composite material are supplied in a ready-to-mount condition but can be machined in the bore, for example, by turning. When machining the bore an R_a value of $2,5 \mu\text{m}$ should be aimed at for the sliding surface. The following machining recommendations have been found to give good results:

- a cutting speed $> 150 \text{ m/min}$,
- a slow feed rate (0,05 to 0,1 mm/revolution),
- a cutting depth $\leq 0,1 \text{ mm}$, and
- a cutting tool of poly-crystalline diamond.

In addition, cooling must be efficient to prevent excessive heating of the plastic with an attendant risk of smearing. The swarf produced must be removed during machining. Both cooling and swarf removal can usually be achieved using compressed air.

Friction

The friction in composite dry sliding bearings is primarily determined by the load, the sliding velocity and the operating temperature. It is also influenced by the roughness of the surface on which the bearing runs, the degree of contamination and the lubrication conditions.

For PTFE composite bearings, the value of the coefficient of friction μ lies between 0,03 and 0,25 depending on the operating conditions. Similar values are found for the POM composite material, but the influence of lubrication is stronger. The lowest values are normally obtained under high specific loads and low sliding velocities, see guideline values for μ in **Diagram 2**. Under particularly unfavourable operating conditions as well as under light loads, the maximum guideline values may even be exceeded. The friction of PTFE composite bearings is increased at temperatures above $+100 \text{ }^\circ\text{C}$.

Stick-slip effects are negligibly small in bearings of both materials.

Fig 3

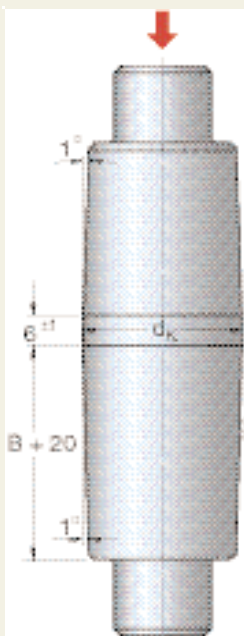

Mandrel

d_K = diameter of calibrating mandrel

B = bushing width

Minimum hardness: 50 HRC

Surface roughness: $R_z \approx 1 \mu\text{m}$

Chemical properties

The chemical resistance of SKF composite dry sliding bearings is primarily determined by the chemical resistance of the steel backing and the sintered tin bronze layer, as the sliding (covering) layers are chemically resistant to many substances. The covering layer of the PTFE composite material is virtually inert because of its PTFE content, although at elevated temperatures molten alkali metals and free fluorine will attack it. The acetal resin covering layer of the POM composite bearings is largely resistant to organic substances.

At room temperature the sintered tin bronze structure has good resistance to sea water, steam, atmospheric influences, salt solutions and sulphuric acid, but not to oxidising acids or media containing ammonia.

All exposed surfaces of the steel backing are electrolytically tin plated but this gives only limited protection against corrosion in most applications. In cases where the bearings are to be exposed to corrosive media, or where there is a danger of corrosion in the contact between the steel backing and the housing material, the backing can be protected by a nickel, chromium or zinc coating applied electrolytically. Further details can be supplied on request.

Diagram 1

Requisite interference of the mandrel

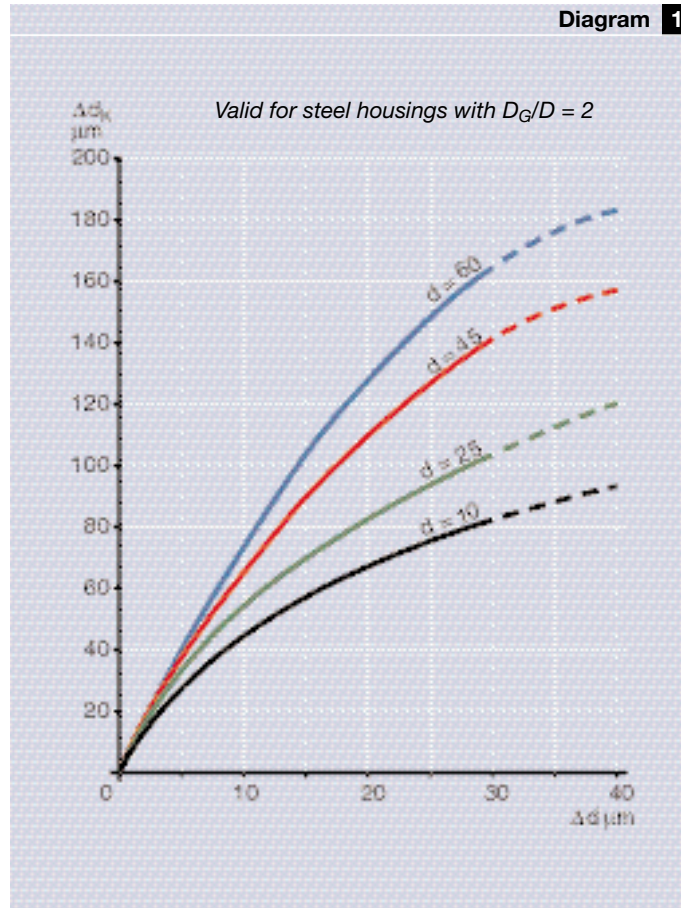
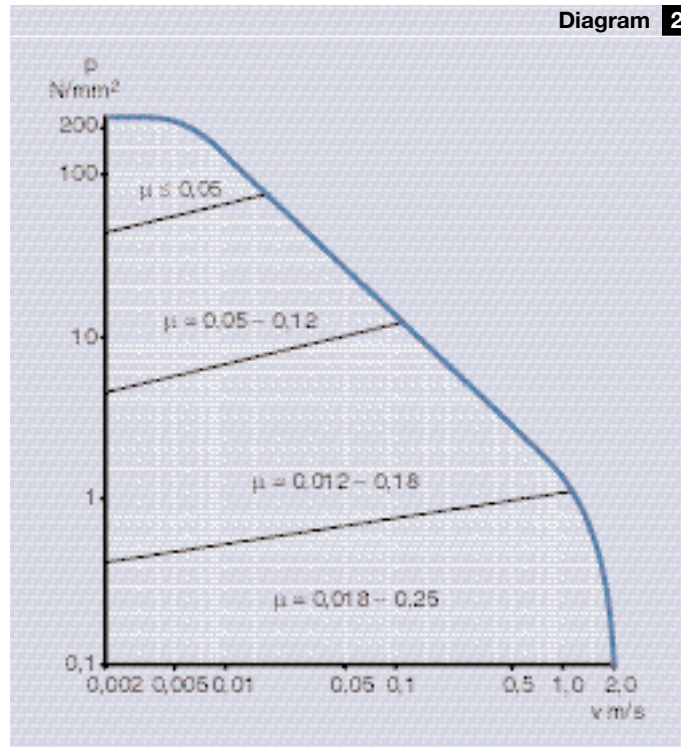

Diagram 2



Guideline values for coefficient of friction of PTFE composite dry sliding bearings

Selection of bearing size

The load carrying ability and wear behaviour of SKF composite dry sliding bearings are governed by the specific conditions pertaining in a particular application. Therefore, any calculation can only provide approximate values. In order to determine the required size of bearing, the load carrying capacity, the applied loads, the service life requirements and operational reliability are all considered. The load carrying capacity is expressed by the basic dynamic load rating C and the basic static load rating C_0 . Values of the load ratings will be found in the product tables.

Basic load ratings

Basic dynamic load ratings

The basic dynamic load rating C is used when calculating dry sliding bearings which are to be dynamically loaded. It is defined as that load, constant in magnitude and direction, under which a given basic rating life (corresponding to a given total distance travelled) can be achieved under constant rotation or oscillating movement at a defined sliding velocity at room temperature. It is assumed in this definition that the load acting on bushings and flanged bushings is purely radial, and the load acting on thrust washers is purely axial and applied at the centre. Dynamic load conditions are essentially oscillating movement or rotation under load, but

also include micro-sliding under variable load (e.g. as a result of vibration) or operation under high-frequency alternating loads. Often a combination of these conditions will be encountered. Whereas oscillating movement or rotation under load usually produces wear, the other conditions may result in fatigue.

The actual load ratings quoted by various manufacturers depend on the way in which they are defined so that it is not always possible to make direct comparisons between them.

Basic static load ratings

The basic static load rating C_0 is defined as the maximum load which an SKF composite bushing, flanged

bushing or thrust washer can support when stationary at room temperature without permanent deformation of the sliding layer being produced which would jeopardise its performance. It is assumed here that the components surrounding the bearing prevent its deformation. At elevated temperatures it is necessary to modify the basic load ratings of the various materials by multiplying the C_0 value by the temperature factor c_3 , which is also valid for dynamically loaded bearings (→ **Diagram 5**). The permissible operating temperature range should also be considered (→ **Table 2**, **page 7**).

Diagram 1

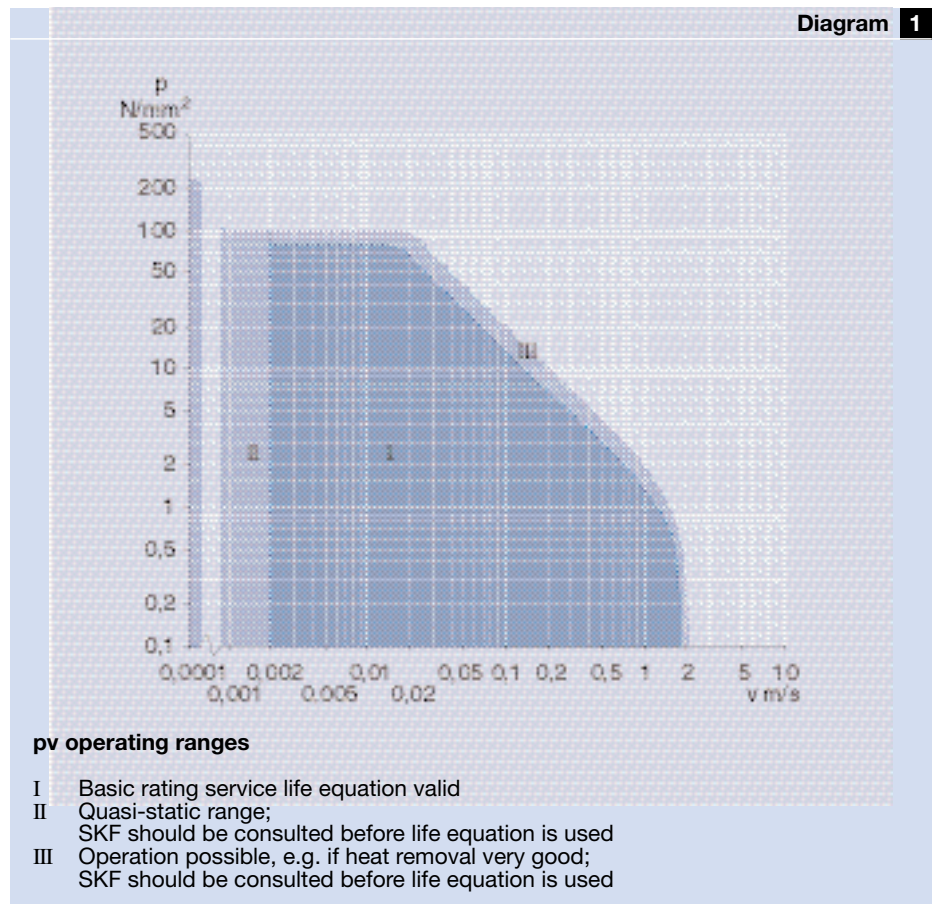

*pv operating range
for PTFE composite
dry sliding bearings*

Service life

The service life of a dry sliding bearing is expressed as a number of oscillations or revolutions, or in operating hours. It depends on the clearance increase occurring under boundary or dry lubrication conditions because of the continuing wear of the sliding contact surfaces, plastic deformation of the sliding layer or fatigue. Depending on the application and sliding layer various degrees of wear or increases in friction may be acceptable. This means that even under apparently similar operating conditions, the service life achieved in practice will differ, simply because the requirements placed on the bearing differ.

In contrast, the lives actually achieved by seemingly identical bearings under identical operating conditions for identical demands are not the same. This scatter of results has been

found both in laboratory endurance tests as well as in field tests. Obviously the actual lives will also be affected by the actual operating conditions – not only the magnitude and type of load but also many other influences which are difficult or even impossible to quantify. These include contamination, corrosion, high frequency load and movement cycles and shock loads.

However, the basic rating service life is a guideline value which is attained or exceeded by the majority of bearings under the test conditions.

Requisite bearing size

The type and mode of action of the load, the expected operating temperature, lubrication and maintenance requirements etc. all influence the choice of bearing type and design.

To determine the requisite size of composite dry sliding bearing to be used, it is necessary to know the basic rating service life which is required for, or appropriate to, a given application. This depends on the type of machine, the duration of operation, the operating conditions and the degree of operational reliability required.

pv operating range

When selecting a suitable size of dry sliding bearing **Diagrams 1** and **2** can be used to check whether a proposed bearing can be used under the given load and at the given sliding velocity. The data required – p (specific bearing load) and v (sliding velocity) – can be calculated using the equations overleaf. If it is found that the operating data lie within range I of the pv diagram, the basic rating service life of the bearing can be determined using the equation given in the following section. If the data lie within range II or III of the diagram, either SKF should be contacted, or pre-trials made to see whether the bearing can be used. Alternatively, a different bearing should be chosen so that the values for p and v fall within the range I.

For flanged bushings it is necessary to check the suitability of the bushing and flange separately.

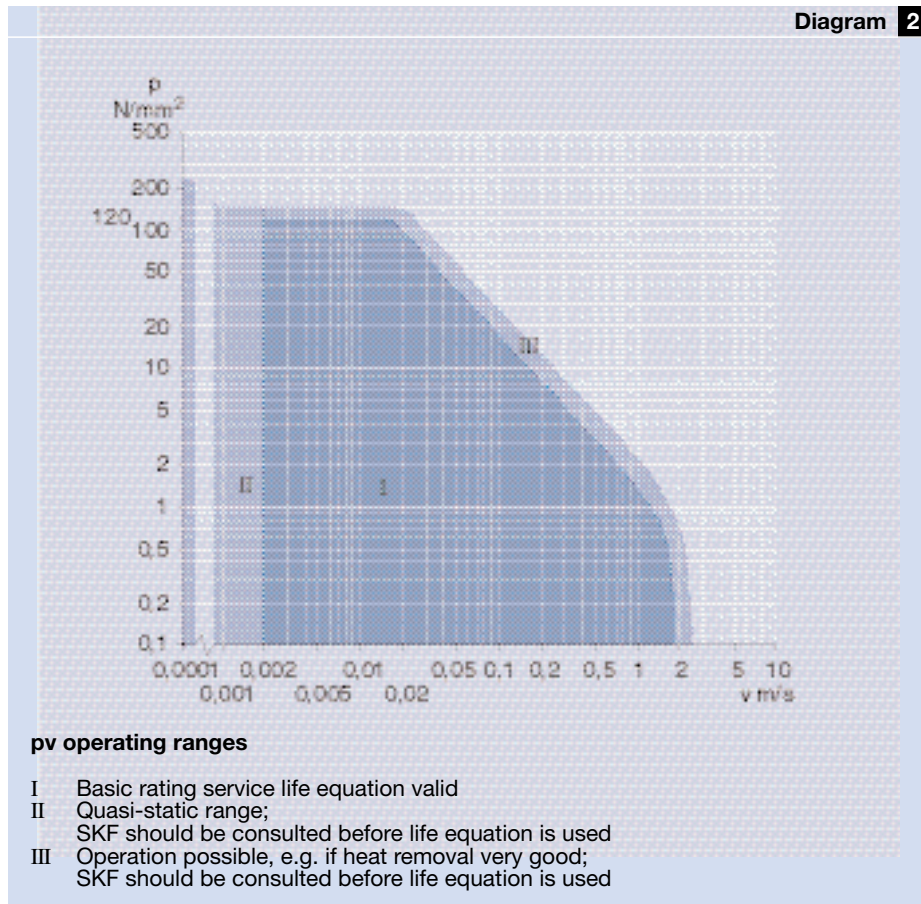

**pv operating range
for POM composite
dry sliding bearings**

Selection of bearing size

Diagram 3

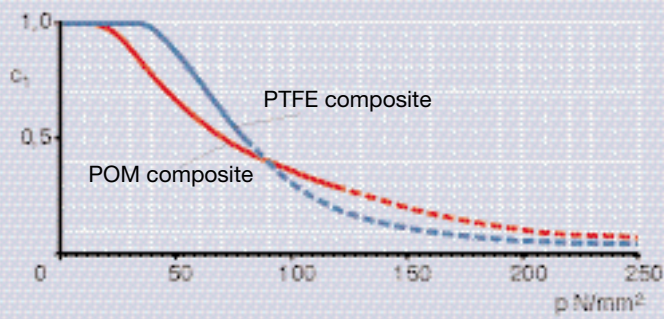

Determination of specific bearing load

The specific bearing load can be determined from

$$p = K \frac{F}{C}$$

where

- p = specific bearing load, N/mm^2
- F = dynamic bearing load, N
- C = basic dynamic load rating, N
- K = specific load factor, N/mm^2
 - = 80 for PTFE composite material
 - = 120 for POM composite material

For flanged bushings it is necessary to calculate the specific load of the bushing and flange separately. When calculating the specific bearing load for the flange the axial basic dynamic load rating C_a should be used instead of C in the above equation. Values of C_a will be found in the product tables.

Determination of sliding velocity

The sliding velocity for SKF composite bushings and thrust washers can be obtained from

$$v = 5,82 \times 10^{-7} d \beta f$$

where

- v = sliding velocity, m/s
- d = bore diameter of bushings and flanged bushings, mm
- = mean diameter of flange of flanged bushings = $0,5 (d + D_1)$, mm
- = mean diameter of thrust washers = $0,5 (d + D)$, mm (= dimension J in product table)
- f = frequency of oscillation, min^{-1} , or rotational speed, r/min
- β = half the angle of oscillation, degrees (\rightarrow fig 1)

A complete oscillation (from point 0 to point 4) = 4β . For rotation, use $\beta = 90^\circ$.

Diagram 4

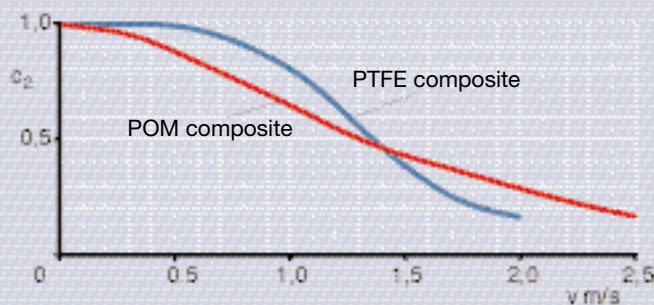

Speed factor c_2

Diagram 5

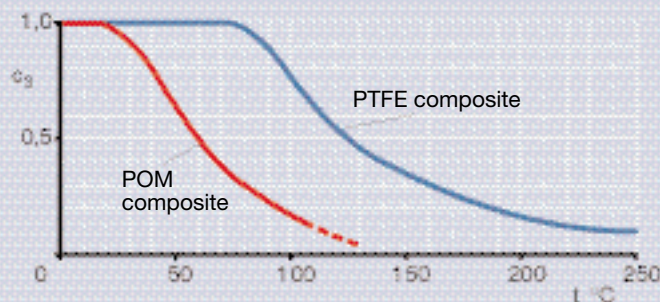

Temperature factor c_3

Diagram 6

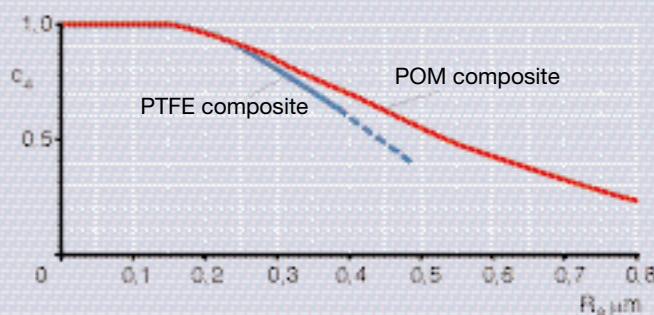

Surface roughness factor c_4

Calculation of service life

Many factors influence the life of a dry sliding bearing, e.g. load, sliding velocity, operating temperature, surface roughness of the surface on which the dry sliding layer runs etc. Any calculation is therefore only approximate.

The values obtained using the equations given below for the basic rating service life are attained by the majority of bearings and are often exceeded. This has been confirmed by rig tests and field experience.

The basic rating service life for SKF PTFE composite and POM composite dry sliding bearings can be calculated from

$$G_h = c_1 c_2 c_3 c_4 c_5 \frac{K_M}{(pv)^n}$$

where

G_h = basic rating service life, operating hours

c_1 = load factor (→ **Diagram 3**)

c_2 = speed factor (→ **Diagram 4**)

c_3 = temperature factor (→ **Diagram 5**)

c_4 = surface roughness factor (→ **Diagram 6**)

c_5 = factor for the type of load
= 1 for point load (i.e. the loaded zone is always at the same position on the bearing circumference)

= 1,5 for rotating load (i.e. the loaded zone moves round the circumference of the bearing)

K_M = factor depending on material and bearing type
= 480 for PTFE composite bushings

= 300 for PTFE composite thrust washers

= 1 900 for POM composite bushings and thrust washers

p = specific bearing load, N/mm²

v = sliding velocity, m/s

n = an exponent

= 1 for PTFE composite bushings and thrust washers

= 1 for $pv \leq 1$ for POM composite bushings and thrust washers

= 3 for $pv > 1$ for POM composite bushings and thrust washers

If loads are very light and/or sliding velocities very low and the value of the product pv

- for PTFE composite bearings is less than the limiting value of 0,025 then the limiting value $pv = 0,025$ should be used for the life calculations.
- for POM composite bearings is less than the limiting value of 0,1 then the limiting value $pv = 0,1$ should be used for the life calculations.

Calculation example

The suspension of a rail vehicle is to be equipped with composite dry sliding bearings at the linkage position of the springs; in this case bushings arranged in pairs are to be used.

Design data:

Pin diameter: $d = 30$ mm

Surface roughness of pin: $R_a = 0,4$ μ m

Operating data:

Radial load at the linkage point:

$F_r = 18\,750$ N

Half angle of oscillation: $\beta = 1^\circ$

(→ **fig 1**)

Frequency of oscillation: $f = 180$ min⁻¹

Operating temperature: $t = 30$ °C

Based on the design characteristics, PTFE composite bushing PCM 303420 B having a basic dynamic load rating $C = 46\,500$ N is chosen. It is necessary to check that the bushing can be used under the given operating conditions and then to calculate the basic rating service life.

As a first check that the bearing size is suitable (→ **Diagram 1**) the specific bearing load p is calculated using

$$p = K \frac{F}{C} = 80 \times \frac{18\,750}{2 \times 46\,500} \approx 16 \text{ N/mm}^2$$

(with the specific load factor $K = 80$ for PTFE composite).

The sliding velocity is calculated using

$$\begin{aligned} v &= 5,82 \times 10^{-7} d \beta f \\ &= 5,82 \times 10^{-7} \times 30 \times 1 \times 180 \\ &= 0,0031 \text{ m/s} \end{aligned}$$

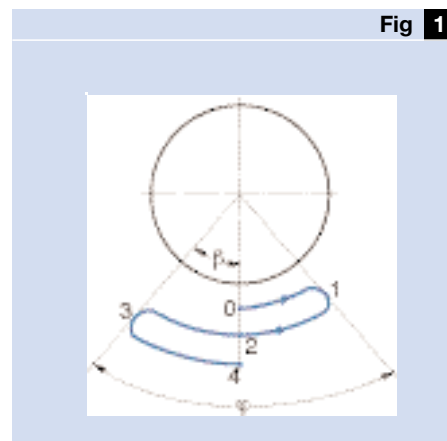

Angle of oscillation

φ = angle of oscillation = 2β

A complete oscillation = 4β
(from point 0 to point 4)

These values are within the permissible range I of the pv diagram for PTFE composite bearings. Furthermore

the load factor $c_1 = 1$ (→ **Diagram 3**),

the speed factor $c_2 = 1$

(→ **Diagram 4**),

the temperature factor $c_3 = 1$

(→ **Diagram 5**),

the surface roughness factor $c_4 = 0,6$

(→ **Diagram 6**), and

the factor for the type of load $c_5 = 1,5$ as the load is rotating.

The value of K_M for PTFE composite bushings = 480. Thus using the basic rating service life equation for SKF composite dry sliding bearings

$$G_h = c_1 c_2 c_3 c_4 c_5 \frac{K_M}{(pv)^n}$$

$$G_h = 1 \times 1 \times 1 \times 0,6 \times 1,5 \times \frac{480}{16 \times 0,0031}$$

$G_h = 8\,700$ operating hours

Application of bearings

Material and surface finish of counterfaces

The factors which are most important to consider when selecting the material and surface finish of the counterface (the surface on which the bearing slides) are the loading conditions (load, angle of oscillation, type of movement etc.) and the environmental influences.

Where there is a risk of corrosion, the counterface must be sufficiently resistant. Corrosion scars in the counterface and the products of corrosion (particulate contamination) increase the surface roughness or are abrasive, thus increasing wear. In such cases the use of stainless steel or a surface treatment such as hard chromium or nickel plating or electrolytic oxidation should be considered.

For PTFE composite and POM composite dry sliding bearing arrangements soft carbon steels having a ground surface are usually adequate for the counterface. The surface roughness R_a (to DIN 4768:1990) should not exceed $0,4 \mu\text{m}$ for PTFE composite bearings and $0,8 \mu\text{m}$ for POM composite bearings. The corresponding R_z values are 3 and $6 \mu\text{m}$, respectively. For more demanding applications the use of hardened shafts is recommended. These should have a surface hardness of at least 50 HRC. Alternatively, hard chromium or nickel plating or some other form of surface treatment should be considered. In all cases R_a should not be greater than $0,3 \mu\text{m}$ ($R_z \leq 2 \mu\text{m}$). The better the surface finish, the better the running properties and the less the wear (→ **Surface roughness factor c_4** , **Diagram 6**, **page 12**).

Shaft and housing tolerances

It is recommended that the seating in the housing bore is machined to tolerance H6 for PTFE composite and POM composite dry sliding bushings (including flanged bushings) having a bore diameter up to and including 4 mm , and to tolerance H7 for larger bearings. If this is done, after mounting, the bore diameter of the bushing and the clearance in the bearing arrangement will lie within the limits quoted in **Tables 1** and **3** for metric sizes of PTFE composite and POM composite dry sliding bushings, respectively, provided the shaft seating also has the recommended tolerance.

The shaft and housing limits for inch-sized bushings are given in **Tables 2** and **4**, respectively, together with the corresponding limits for the bushing bore diameter after mounting and the operating clearance.

The values quoted are for the operating clearance at room temperature. If the operating temperature is higher than this it is expected that the operating clearance of

- PTFE composite bushings will be reduced by $0,0016 \text{ mm}$ and
- POM composite bushings will be reduced by $0,005 \text{ mm}$

for every $20 \text{ }^\circ\text{C}$ temperature increase. The actual operating clearance can be increased or decreased within the recommended limits by matching shaft and housing bores having appropriate values within the specified limits.

If in certain applications very easy running is required, for example, or if the bearing is only lightly loaded, it is recommended that maximum values for the operating clearance should be aimed for.

The recommended tolerances and guideline limits quoted in the tables are valid for steel and cast iron housings.

Where light alloy housings are used, a greater degree of interference may be required because of the different thermal expansion characteristics. There is otherwise a risk that the greater thermal expansion of the housing would no longer provide radial location for the bushing and that the operating clearance would be too large.

If it is not possible to adopt a greater interference for mounting reasons, or because of the force required to press the bushing into the housing bore, it is possible to use an adhesive to retain the bushing in position. In special cases it may be necessary, by selecting a suitable tolerance for the shaft, to prevent an inadmissible increase in operating clearance.

PTFE composite bushings (metric sizes)
Shaft and housing tolerances, bearing clearance

Table 1

Bushing dimensions			Diameter limits		Housing bore		Bore diameter of mounted bushing		Operating clearance or preload (-)		
Bore diameter	Outside diameter	Wall thickness	Shaft (f7 for d ≤ 75 mm) (h8 for d > 75 mm)		Housing bore (H7)		Bore diameter of mounted bushing		Operating clearance or preload (-)		
d	D	max	min	max	min	max	min	max	min	max	
mm			mm						µm		
3	4,5	0,750	0,730	3,000(h6)	2,994(h6)	4,508(H6)	4,500(H6)	3,048	3,000	0	54
4	5,5	0,750	0,730	4,000(h6)	3,992(h6)	5,508(H6)	5,500(H6)	4,048	4,000	0	56
5	7	1,007	0,981	4,990	4,978	7,015	7,000	5,053	4,986	-4	75
6	8	1,007	0,981	5,990	5,978	8,015	8,000	6,053	5,986	-4	75
7	9	1,007	0,981	6,987	6,972	9,015	9,000	7,053	6,986	-1	81
8	10	1,007	0,981	7,987	7,972	10,015	10,000	8,053	7,986	-1	81
10	12	1,007	0,981	9,987	9,972	12,018	12,000	10,056	9,986	-1	84
12	14	1,007	0,981	11,984	11,966	14,018	14,000	12,056	11,986	2	90
13	15	1,007	0,981	12,984	12,966	15,018	15,000	13,056	12,986	2	90
14	16	1,007	0,981	13,984	13,966	16,018	16,000	14,056	13,986	2	90
15	17	1,007	0,981	14,984	14,966	17,018	17,000	15,056	14,986	2	90
16	18	1,007	0,981	15,984	15,966	18,018	18,000	16,056	15,986	2	90
17	19	1,007	0,981	16,984	16,966	19,021	19,000	17,059	16,986	2	93
18	20	1,007	0,981	17,984	17,966	20,021	20,000	18,059	17,986	2	93
20	23	1,507	1,475	19,980	19,959	23,021	23,000	20,071	19,986	6	112
22	25	1,507	1,475	21,980	21,959	25,021	25,000	22,071	21,986	6	112
24	27	1,507	1,475	23,980	23,959	27,021	27,000	24,071	23,986	6	120
25	28	1,507	1,475	24,980	24,959	28,021	28,000	25,071	24,986	6	120
28	32	2,007	1,971	27,980	27,959	32,025	32,000	28,083	27,986	6	124
30	34	2,007	1,971	29,980	29,959	34,025	34,000	30,083	29,986	6	124
32	36	2,007	1,971	31,975	31,950	36,025	36,000	32,083	31,986	11	133
35	39	2,007	1,971	34,975	34,950	39,025	39,000	35,083	34,986	11	133
37	40	1,507	1,475	36,975	36,950	40,025	40,000	37,075	36,986	11	125
40	44	2,007	1,971	39,975	39,950	44,025	44,000	40,083	39,986	11	133
45	50	2,508	2,462	44,975	44,950	50,025	50,000	45,101	44,984	9	151
50	55	2,508	2,462	49,975	49,950	55,030	55,000	50,106	49,984	14	166
55	60	2,508	2,462	54,970	54,940	60,030	60,000	55,106	54,984	14	166
60	65	2,508	2,462	59,970	59,940	65,030	65,000	60,106	59,984	14	166
65	70	2,508	2,462	64,970	64,940	70,030	70,000	65,106	64,984	14	166
70	75	2,508	2,462	69,970	69,940	75,030	75,000	70,106	69,984	14	166
75	80	2,508	2,462	74,970	74,940	80,030	80,000	75,106	74,984	14	166
80	85	2,490	2,440	80,000	79,954	85,035	85,000	80,155	80,020	20	201
85	90	2,490	2,440	85,000	84,946	90,035	90,000	85,155	85,020	20	206
90	95	2,490	2,440	90,000	89,946	95,035	95,000	90,155	90,020	20	206
95	100	2,490	2,440	95,000	94,946	100,035	100,000	95,155	95,020	20	206
100	105	2,490	2,440	100,000	99,946	105,035	105,000	100,155	100,020	20	206
105	110	2,490	2,440	105,000	104,946	110,035	110,000	105,155	105,020	20	206
110	115	2,490	2,440	110,000	109,946	115,035	115,000	110,155	110,020	20	206
115	120	2,490	2,440	115,000	114,946	120,035	120,000	115,155	115,020	20	206
120	125	2,465	2,415	120,000	119,946	125,040	125,000	120,210	120,070	70	264
125	130	2,465	2,415	125,000	124,937	130,040	130,000	125,210	125,070	70	273
130	135	2,465	2,415	130,000	129,937	135,040	135,000	130,210	130,070	70	273
135	140	2,465	2,415	135,000	134,937	140,040	140,000	135,210	135,070	70	273
140	145	2,465	2,415	140,000	139,937	145,040	145,000	140,210	140,070	70	273
150	155	2,465	2,415	150,000	149,937	155,040	155,000	150,210	150,070	70	273

Application of bearings

PTFE composite bushings (metric sizes) Shaft and housing tolerances, bearing clearance

Continuation of Table 1

Bushing dimensions				Diameter limits Shaft (h8)		Housing bore (H7)		Bore diameter of mounted bushing		Operating clearance or preload (-)	
Bore diameter	Outside diameter	Wall thickness		max	min	max	min	max	min	min	max
d	D	max	min	max	min	max	min	max	min	min	max
mm				mm				µm			
160	165	2,465	2,415	160,000	159,937	165,040	165,000	160,210	160,070	70	273
180	185	2,465	2,415	180,000	179,937	185,046	185,000	180,216	180,070	70	279
200	205	2,465	2,415	200,000	199,928	205,046	205,000	200,216	200,070	70	288
210	215	2,465	2,415	210,000	209,928	215,046	215,000	210,216	210,070	70	288
220	225	2,465	2,415	220,000	219,928	225,046	225,000	220,216	220,070	70	288
250	255	2,465	2,415	250,000	249,928	255,052	255,000	250,222	250,070	70	294
300	305	2,465	2,415	300,000	299,919	305,052	305,000	300,222	300,070	70	303

PTFE composite bushings (inch sizes)
Shaft and housing tolerances, bearing clearance

Table 2

Bushing dimensions			Diameter limits				Bore diameter of mounted bushing		Operating clearance or preload (-)		
Bore diameter	Outside diameter	Wall thickness	Shaft		Housing bore						
d	D	max	min	max	min	max	min	max	min	max	
inch/mm			inch/mm						μinch/μm		
0,125 3,175	0,1875 4,763	0,0316 0,803	0,0308 0,783	0,1243 3,157	0,1236 3,139	0,1878 4,770	0,1873 4,757	0,1261 3,204	0,1241 3,151	-0,24 -6	2,56 65
0,1562 3,969	0,2188 5,556	0,0316 0,803	0,0308 0,783	0,1554 3,947	0,1547 3,929	0,2191 5,565	0,2186 5,552	0,157 3,999	0,1554 3,946	-0,04 -1	2,76 70
0,1875 4,763	0,25 6,35	0,0316 0,803	0,0308 0,783	0,1865 4,737	0,1858 4,719	0,2503 6,358	0,2497 6,342	0,1887 4,792	0,1865 4,736	-0,04 -1	2,87 73
0,25 6,35	0,3125 7,938	0,0316 0,803	0,0308 0,783	0,2490 6,325	0,2481 6,302	0,3128 7,945	0,3122 7,930	0,251 6,379	0,2490 6,324	-0,04 -1	3,03 77
0,3125 7,938	0,375 9,525	0,0316 0,803	0,0308 0,783	0,3115 7,912	0,3106 7,889	0,3753 9,533	0,3747 9,517	0,3137 7,967	0,3115 7,911	-0,04 -1	3,07 78
0,375 9,525	0,4687 11,906	0,0472 1,198	0,0461 1,172	0,3740 9,500	0,3731 9,477	0,4691 11,915	0,4684 11,897	0,3768 9,571	0,3741 9,501	0,04 1	3,70 94
0,4375 11,113	0,5312 13,494	0,0472 1,198	0,0461 1,172	0,4365 11,087	0,4355 11,062	0,5316 13,503	0,5309 13,485	0,4393 11,159	0,4366 11,089	0,08 2	3,82 97
0,5 12,7	0,5937 15,081	0,0472 1,198	0,0461 1,172	0,4990 12,675	0,4980 12,649	0,5941 15,090	0,5934 15,072	0,5018 12,746	0,4991 12,676	0,04 1	3,82 97
0,5625 14,288	0,6562 16,669	0,0472 1,198	0,0461 1,172	0,5615 14,262	0,5605 14,237	0,6566 16,678	0,6559 16,660	0,5643 14,334	0,5616 14,264	0,08 2	3,82 97
0,625 15,875	0,7187 18,256	0,0472 1,198	0,0461 1,172	0,6240 15,850	0,6230 15,824	0,7192 18,268	0,7184 18,247	0,6269 15,924	0,6241 15,851	0,04 1	3,94 100
0,6875 17,463	0,7812 19,844	0,0472 1,198	0,0461 1,172	0,6865 17,437	0,6865 17,412	0,7817 19,855	0,7809 19,835	0,6894 17,511	0,6866 17,439	0,08 2	3,90 99
0,75 19,05	0,875 22,225	0,0627 1,592	0,0614 1,560	0,7491 19,027	0,7479 18,997	0,8755 22,238	0,8747 22,217	0,7527 19,118	0,7493 19,033	0,24 6	4,76 121
0,875 22,225	1 25,4	0,0627 1,592	0,0614 1,560	0,8741 22,202	0,8729 22,172	1,0005 25,413	0,9997 25,392	0,8777 22,293	0,8743 22,208	0,24 6	4,76 121
1 25,4	1,125 28,575	0,0627 1,592	0,0614 1,560	0,9991 25,377	0,9979 25,347	1,1256 28,590	1,1246 28,565	1,0028 25,470	0,9993 25,381	0,16 4	4,84 123
1,125 28,575	1,2812 32,544	0,0784 1,991	0,077 1,955	1,1238 28,545	1,1226 28,514	1,2818 32,558	1,2808 32,532	1,1279 28,648	1,1240 28,550	0,20 5	5,28 134
1,25 31,75	1,4062 35,719	0,0784 1,991	0,077 1,955	1,2488 31,720	1,2472 31,679	1,4068 35,733	1,4058 35,707	1,2529 31,823	1,2490 31,725	0,20 5	5,57 144
1,375 34,925	1,5312 38,894	0,0784 1,991	0,077 1,955	1,3738 34,895	1,3722 34,854	1,5318 38,908	1,5308 38,882	1,3779 34,998	1,3740 34,900	0,20 5	5,57 144
1,5 38,1	1,6562 42,069	0,0784 1,991	0,077 1,955	1,4988 38,070	1,4972 38,029	1,6568 42,083	1,6558 42,057	1,5029 38,173	1,4990 38,075	0,20 5	5,57 144
1,625 41,275	1,7812 45,244	0,784 1,991	0,077 1,955	1,6238 41,245	1,6222 41,204	1,7818 45,258	1,7808 45,232	1,6279 41,348	1,6240 41,250	0,20 5	5,57 144
1,75 44,45	1,9375 49,213	0,0939 2,386	0,0921 2,340	1,7487 44,417	1,7471 44,376	1,9381 49,228	1,9371 49,202	1,7539 44,548	1,7492 44,430	0,51 13	6,77 172

Application of bearings

PTFE composite bushings (inch sizes) Shaft and housing tolerances, bearing clearance

Continuation of Table **2**

Bushing dimensions		Wall thickness		Diameter limits Shaft		Housing bore		Bore diameter of mounted bushing		Operating clearance or preload (-)	
Bore diameter	Outside diameter	max	min	max	min	max	min	max	min	max	
d	D	max	min	max	min	max	min	max	min	max	
inch/mm				inch/mm				μinch/μm			
1,875 47,625	2,0625 52,388	0,0939 2,386	0,0921 2,340	1,8737 47,592	1,8721 47,551	2,0633 52,408	2,0621 52,377	1,8791 47,728	1,8742 47,605	0,51 13	6,97 177
2 50,8	2,1875 55,563	0,0939 2,386	0,0921 2,340	1,9987 50,767	1,9969 50,721	2,1883 55,583	2,1871 55,552	2,0041 50,903	1,9992 50,780	0,51 13	7,17 182
2,25 57,15	2,4375 61,913	0,0925 2,35	0,0906 2,30	2,2507 57,168	2,2489 57,122	2,4377 61,918	2,4365 61,887	2,2566 57,318	2,2515 57,187	0,75 19	7,72 196
2,5 63,5	2,6875 68,263	0,0925 2,35	0,0906 2,30	2,5011 63,528	2,4993 63,482	2,6881 68,278	2,6869 68,247	2,5070 63,678	2,5019 63,547	0,75 19	7,72 196
2,75 69,85	2,9375 74,613	0,0925 2,35	0,0906 2,30	2,7500 69,850	2,7482 69,804	2,9370 74,600	2,9358 74,569	2,7559 70,000	2,7507 69,869	0,75 19	7,72 196
3 76,2	3,1875 80,963	0,0925 2,35	0,0906 2,30	3,0000 76,200	2,9982 76,154	3,1872 80,955	3,1858 80,919	3,0061 76,355	3,0007 76,219	0,75 19	7,91 201
3,5 88,9	3,6875 93,663	0,0925 2,35	0,0906 2,30	3,5000 88,900	3,4978 88,844	3,6872 93,655	3,6858 93,615	3,5061 89,055	3,5007 88,919	0,75 19	8,31 211
4 101,6	4,1875 106,363	0,0925 2,35	0,0906 2,30	4,0000 101,600	3,9978 101,544	4,1872 106,355	4,1858 106,319	4,0061 101,755	4,0007 101,619	0,75 19	8,31 211
5 127	5,1875 131,763	0,0915 2,325	0,0896 2,275	4,9986 126,964	4,9961 126,901	5,186 131,724	5,1844 131,684	5,0067 127,174	5,0013 127,034	2,6 70	10,7 273
6 152,4	6,1875 157,163	0,0915 2,325	0,0896 2,275	6,0000 152,400	5,9975 152,337	6,1874 157,160	6,1858 157,119	6,0083 152,610	6,0027 152,469	2,72 69	10,7 273
7 177,8	7,1875 182,563	0,0915 2,325	0,0896 2,275	6,9954 177,683	6,9929 177,620	7,1830 182,448	7,1812 182,403	7,0039 177,888	6,9981 177,753	2,76 70	10,9 278

POM composite bushings (metric sizes)
Shaft and housing tolerances, bearing clearance

Table 3

Bushing dimensions			Diameter limits				Housing bore		Bore diameter of mounted bushing		Operating clearance	
Bore diameter	Outside diameter	Wall thickness	Shaft (h8)		Housing bore (H7)		Bore diameter of mounted bushing		Operating clearance			
d	D	max min	max	min	max	min	max	min	min	max		
mm			mm						µm			
8	10	0,980	0,955	8,000	7,978	10,015	10,000	8,105	8,040	40	127	
10	12	0,980	0,955	10,000	9,978	12,018	12,000	10,108	10,040	40	130	
12	14	0,980	0,955	12,000	11,973	14,018	14,000	12,108	12,040	40	135	
13	15	0,980	0,955	13,000	12,973	15,018	15,000	13,108	13,040	40	135	
14	16	0,980	0,955	14,000	13,973	16,018	16,000	14,108	14,040	40	135	
15	17	0,980	0,955	15,000	14,973	17,018	17,000	15,108	15,040	40	135	
16	18	0,980	0,955	16,000	15,973	18,018	18,000	16,108	16,040	40	135	
18	20	0,980	0,955	18,000	17,973	20,021	20,000	18,111	18,040	40	138	
20	23	1,475	1,445	20,000	19,967	23,021	23,000	20,131	20,050	50	164	
22	25	1,475	1,445	22,000	21,967	25,021	25,000	22,131	22,050	50	164	
24	27	1,475	1,445	24,000	23,967	27,021	27,000	24,131	24,050	50	164	
25	28	1,475	1,445	25,000	24,967	28,021	28,000	25,131	25,050	50	164	
28	32	1,970	1,935	28,000	27,967	32,025	32,000	28,155	28,060	60	188	
30	34	1,970	1,935	30,000	29,967	34,025	34,000	30,155	30,060	60	188	
32	36	1,970	1,935	32,000	31,961	36,025	36,000	32,155	32,060	60	194	
35	39	1,970	1,935	35,000	34,961	39,025	39,000	35,155	35,060	60	194	
37	40	1,475	1,445	37,000	36,961	40,025	40,000	37,135	37,050	50	174	
40	44	1,970	1,935	40,000	39,961	44,025	44,000	40,155	40,060	60	194	
45	50	2,460	2,415	45,000	44,961	50,025	50,000	45,195	45,080	80	234	
50	55	2,460	2,415	50,000	49,961	55,030	55,000	50,200	50,080	80	239	
55	60	2,460	2,415	55,000	54,954	60,030	60,000	55,200	55,080	80	246	
60	65	2,460	2,415	60,000	59,954	65,030	65,000	60,200	60,080	80	246	
65	70	2,450	2,385	65,000	64,954	70,030	70,000	65,260	65,100	100	306	
70	75	2,450	2,385	70,000	69,954	75,030	75,000	70,260	70,100	100	306	
75	80	2,450	2,385	75,000	74,954	80,030	80,000	75,260	75,100	100	306	
80	85	2,450	2,385	80,000	79,954	85,035	85,000	80,265	80,100	100	311	
85	90	2,450	2,385	85,000	84,946	90,035	90,000	85,265	85,100	100	319	
90	95	2,450	2,385	90,000	89,946	95,035	95,000	90,265	90,100	100	319	
95	100	2,450	2,385	95,000	94,946	100,035	100,000	95,265	95,100	100	319	
100	105	2,450	2,385	100,000	99,946	105,035	105,000	100,265	100,100	100	319	
105	110	2,450	2,385	105,000	104,946	110,035	110,000	105,265	105,100	100	319	
110	115	2,450	2,385	110,000	109,946	115,035	115,000	110,265	110,100	100	319	
115	120	2,450	2,385	115,000	114,946	120,035	120,000	115,265	115,100	100	319	
120	125	2,450	2,385	120,000	119,946	125,040	125,000	120,270	120,100	100	324	
125	130	2,450	2,385	125,000	124,937	130,040	130,000	125,270	125,100	100	333	
130	135	2,450	2,385	130,000	129,937	135,040	135,000	130,270	130,100	100	333	
135	140	2,450	2,385	135,000	134,937	140,040	140,000	135,270	135,100	100	333	
140	145	2,450	2,385	140,000	130,937	145,040	145,000	140,270	140,100	100	333	
150	155	2,450	2,385	150,000	149,937	155,040	155,000	150,270	150,100	100	333	
160	165	2,450	2,385	160,000	159,937	165,040	165,000	160,270	160,100	100	333	
180	185	2,450	2,385	180,000	179,937	185,046	185,000	180,276	180,100	100	339	
190	195	2,450	2,385	190,000	189,928	195,046	195,000	190,276	190,100	100	348	
210	215	2,450	2,385	210,000	209,928	215,046	215,000	210,276	210,100	100	348	
280	285	2,450	2,385	280,000	279,919	285,052	285,000	280,282	280,100	100	363	

Application of bearings

POM composite bushings (inch sizes) Shaft and housing tolerances, bearing clearance

Table 4

Bushing dimensions			Diameter limits				Housing bore		Bore diameter of mounted bushing		Operating clearance	
Bore diameter	Outside diameter	Wall thickness	Shaft		Housing bore		Bore diameter of mounted bushing		Operating clearance			
d	D	max	min	max	min	max	min	max	min	max		
inch/mm			inch/mm				μinch/μm					
0,375 9,525	0,4687 11,906	0,051 1,295	0,050 1,270	0,3648 9,266	0,3639 9,243	0,4694 11,923	0,4687 11,905	0,3694 9,383	0,3667 9,315	1,93 49	5,51 140	
0,4375 11,113	0,5312 13,494	0,051 1,295	0,050 1,270	0,4273 10,853	0,4263 10,828	0,5319 13,510	0,5312 13,493	0,4319 10,970	0,4293 10,903	1,97 50	5,59 142	
0,5 12,7	0,5937 15,081	0,051 1,295	0,050 1,270	0,4897 12,438	0,4887 12,413	0,5944 15,098	0,5937 15,080	0,4944 12,558	0,4917 12,490	2,05 52	5,71 145	
0,5625 14,288	0,6562 16,669	0,051 1,295	0,050 1,270	0,5522 14,026	0,5512 14,001	0,6569 16,685	0,6562 16,667	0,5569 14,145	0,5543 14,078	2,05 52	5,67 144	
0,625 15,875	0,7187 18,256	0,051 1,295	0,050 1,270	0,6146 15,611	0,6136 15,585	0,7195 18,275	0,7187 18,255	0,6195 15,735	0,6167 15,665	2,13 54	5,91 150	
0,6875 17,463	0,7812 19,844	0,051 1,295	0,050 1,270	0,6770 17,196	0,6760 17,170	0,7820 19,863	0,7812 19,843	0,6820 17,323	0,6793 17,253	2,24 57	6,02 153	
0,75 19,05	0,875 22,225	0,0669 1,699	0,0657 1,669	0,7390 18,771	0,7378 18,740	0,8758 22,245	0,8750 22,225	0,7444 18,907	0,7412 18,827	2,20 56	6,57 167	
0,875 22,225	1 25,4	0,0669 1,699	0,0657 1,669	0,8639 21,943	0,8627 21,913	1,0008 25,420	1,0000 25,400	0,8694 22,082	0,8662 22,002	2,32 59	6,65 169	
1 25,4	1,125 28,575	0,0669 1,699	0,0657 1,669	0,9888 25,116	0,9876 25,085	1,1258 28,595	1,1250 28,575	0,9944 25,257	0,9912 25,177	2,40 61	6,77 172	
1,125 28,575	1,2812 32,544	0,0824 2,093	0,081 2,057	1,1138 28,291	1,1126 28,260	1,2822 32,568	1,2812 32,543	1,1202 28,454	1,1164 28,357	2,60 66	7,64 194	
1,25 31,75	1,4062 35,719	0,0824 2,093	0,081 2,057	1,2387 31,463	1,2371 31,422	1,4072 35,743	1,4062 35,718	1,2452 31,629	1,2414 31,532	2,72 69	8,15 207	
1,375 34,925	1,5312 38,894	0,0824 2,093	0,081 2,057	1,3635 34,633	1,3619 34,592	1,5322 38,918	1,5312 38,893	1,3702 34,804	1,3664 34,707	2,91 74	8,35 212	
1,5 38,1	1,6562 42,069	0,0824 2,093	0,081 2,057	1,4884 37,805	1,4868 37,765	1,6572 42,093	1,6562 42,068	1,4952 37,979	1,4914 37,882	3,03 77	8,43 214	
1,625 41,275	1,7812 45,244	0,0824 2,093	0,081 2,057	1,6133 40,978	1,6117 40,937	1,7822 45,268	1,7812 45,243	1,6202 41,154	1,6164 41,057	3,11 79	8,54 217	
1,75 44,45	1,9375 49,213	0,098 2,489	0,0962 2,443	1,7383 44,153	1,7367 44,112	1,9385 49,238	1,9375 49,213	1,7461 44,352	1,7415 44,235	3,23 82	9,45 240	
1,875 47,625	2,0625 52,388	0,098 2,489	0,0962 2,443	1,8632 47,325	1,8616 47,285	2,0637 52,418	2,0625 52,388	1,8713 47,532	1,8665 47,410	3,35 85	9,72 247	
2 50,8	2,1875 55,563	0,098 2,489	0,0962 2,443	1,9881 50,498	1,9863 50,452	2,1887 55,593	2,1875 55,563	1,9963 50,707	1,9915 50,585	3,43 87	10,0 255	
2,25 57,15	2,4375 61,913	0,098 2,489	0,0962 2,443	2,2378 56,840	2,2360 56,794	2,4387 61,943	2,4375 61,913	2,2463 57,057	2,2415 56,935	3,74 95	10,4 263	
2,5 63,5	2,6875 68,263	0,098 2,489	0,0962 2,443	2,4875 63,183	2,4857 63,137	2,6887 68,293	2,6875 68,263	2,4963 63,407	2,4915 63,285	4,02 102	10,6 270	
2,75 69,85	2,9375 74,613	0,0991 2,517	0,0965 2,451	2,7351 69,472	2,7333 69,426	2,9387 74,643	2,9375 74,613	2,7457 69,741	2,7393 69,579	4,21 107	12,4 315	

POM composite bushings (inch sizes)
Shaft and housing tolerances, bearing clearance

Continuation of Table **4**

Bushing dimensions		Wall thickness		Diameter limits Shaft		Housing bore		Bore diameter of mounted bushing		Operating clearance	
Bore diameter	Outside diameter	max	min	max	min	max	min	max	min	min	max
d	D										
inch/mm				inch/mm				μinch/μm			
3	3,1875	0,0991	0,0965	2,9849	2,9831	3,1889	3,1875	2,9959	2,9893	4,41	12,8
76,2	80,963	2,517	2,451	75,817	75,771	80,998	80,963	76,096	75,929	112	325
3,5	3,6875	0,0991	0,0965	3,4844	3,4822	3,6889	3,6875	3,4959	3,4893	4,92	13,7
88,9	93,663	2,517	2,451	88,504	88,448	93,698	93,663	88,796	88,629	125	348
4	4,1875	0,0991	0,0965	3,9839	3,9817	4,1889	4,1875	3,9959	3,9893	5,43	14,2
101,6	106,363	2,517	2,451	101,191	101,135	106,398	106,363	101,496	101,329	138	361

Design of associated components

Bushings

The surface of the shaft on which the bushing runs, i.e. the counterface, should always be wider than the actual bushing – particularly where axial displacement of the shaft relative to the housing may occur as a result of changes in shaft length – in order to prevent step formation in the sliding surface.

To ease mounting, shaft ends and housing bores should have a lead-in chamfer with an angle of 10 to 15° (→ fig 1). It is then easier to press the bushings into the housing bore and to insert the shaft into the bushing bore without the risk of damaging the sliding surface.

The housing shoulders intended for axial location of the bushing should have a diameter which is equal to or greater than $d + 0,8$ mm.

Where PTFE composite bushings operate without lubricant it is especially important to accurately align bearing positions. If misalignment between the positions cannot be avoided, it is necessary to take steps at the design stage to prevent inadmissibly high edge stresses from occurring. For

example, the housing bore seating should be relieved at both sides, or a wider bushing should be used so that it extends beyond the housing bore seating at both sides (→ fig 2).

If errors of alignment have to be compensated for and the operating conditions permit the use of POM composite, then bushings of this material should be chosen. The covering layer of this material can be machined to a minimum degree after the bushing has been mounted in a housing bore.

Flanged bushings and thrust washers

For shafts which not only need radial support, but also require axial location, flanged bushings or a combination of bushing and thrust washer (→ fig 3) can be used, depending on the magnitude of the axial load. The use of flanged bushings or thrust washers is advantageous even where axial loads are small, particularly where suitable surfaces are not available to take the thrust, either because the material or its finish is unsuitable.

It should be remembered that the counterface should completely cover the sliding surface of the thrust washer and the flange of a flanged bushing (→ fig 4). For bearing arrangements where flanged bushings are used the

transition from housing bore to abutment should be chamfered so that it does not contact the bushing at the transition to the flange (→ fig 5).

Thrust washers are generally located radially in a turned recess in the housing (→ fig 3) and secured by a dowel pin or grub screw to prevent them from rotating. The appropriate dimensions for this type of location are given in the product tables. If a recess cannot be provided in the housing for some reason, the thrust washer can be attached to the housing by two pins or screws (→ fig 6) or by gluing. The heads of the pins or screws must be recessed to at least 0,3 mm below the sliding surface and the entire surface of the thrust washer must be supported.

Lead-in chamfers for housing bores and shaft ends

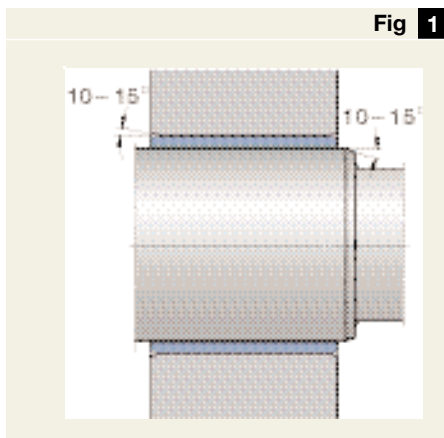

Bushing extending beyond the bearing seating in the housing at both sides to prevent inadmissibly high edge stresses

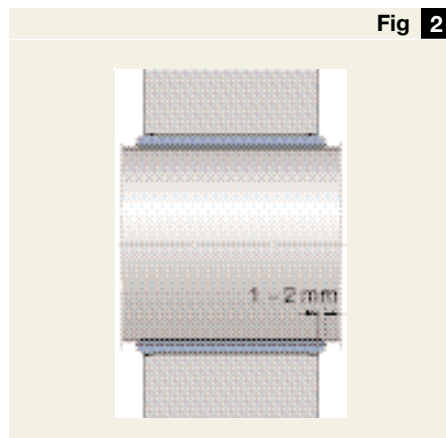

Combination of bushing and thrust washer

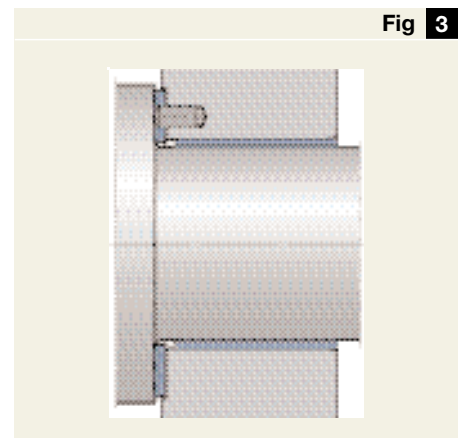
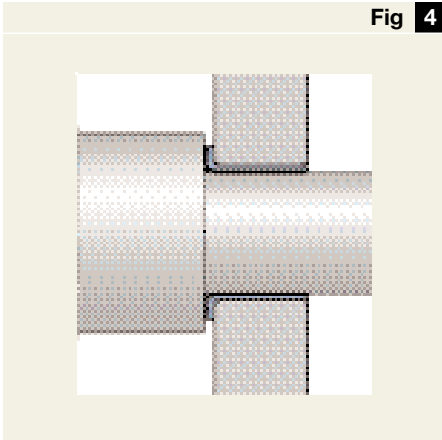
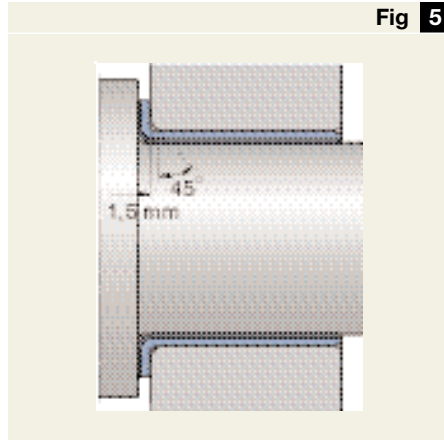

Fig 4



The mating surface should cover the entire surface of the flange

Fig 5



The transition between housing bore and support surface must be sufficiently large

Fig 6

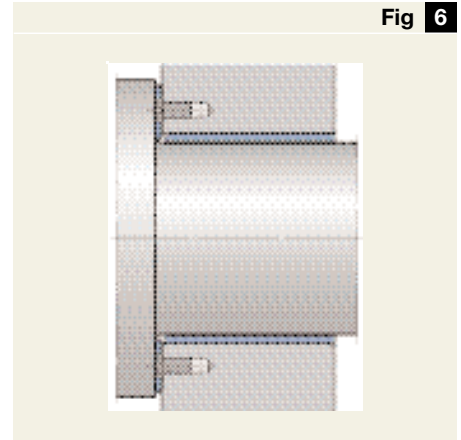

Thrust washer secured by two grub screws

Seals

The service life of composite dry sliding bearings is decisively influenced by the seals used. When selecting suitable seals it is necessary to consider, for example, the design, the available space and the justifiable expense.

Composite dry sliding bearings, in particular those of the POM composite, are able to embed contaminant particles and are thus relatively insensitive to contamination. They generally require no special protection against normal airborne dirt. If, however, the bearing position is subjected to heavier contamination it should be sealed off from the outside. Simple and effi-

cient sealing can be obtained if adjacent components can also serve as seals (→ **fig 7**). Radial shaft seals with low cross section, e.g. of the G design, provide adequate protection for composite dry sliding bearings in normal cases (→ **fig 8**). If the demands placed on the sealing arrangement are high, it may be necessary to resort to special seals of rubber, plastic or similar materials (→ **fig 9**).

Under very rough conditions, particularly where sand or clay contaminants occur, rubber or plastic seals usually have a very short life. Good “sealing” will be achieved in such cases by periodic relubrication, if the operating conditions permit.

Adjacent components serve as seals

Fig 7

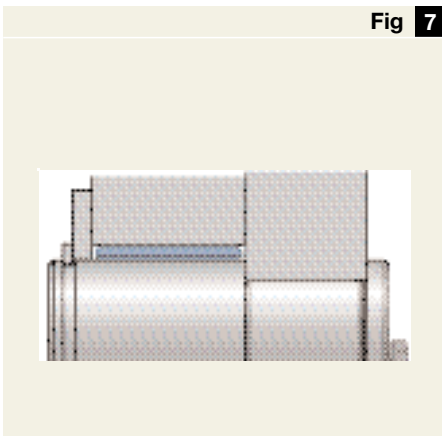

A shaft seal with low cross sectional height can be used

Fig 8

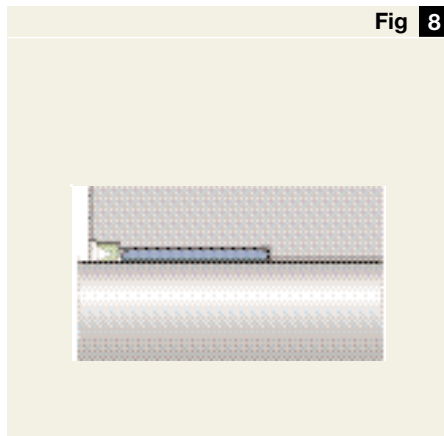

Sealing with a wiper-scraper seal of nitrile rubber

Fig 9

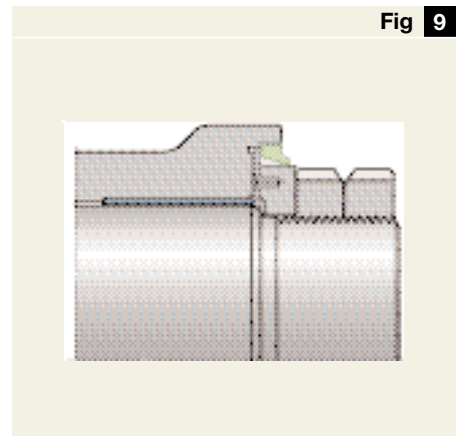

Lubrication

Fig 1

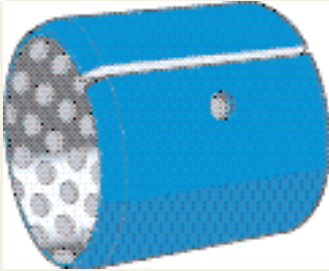

POM composite bushing with lubrication hole

PTFE composite bearings

PTFE composite bearings have good dry sliding characteristics and do not require lubrication. The presence or continuous supply of oil or other fluid may be advantageous, however. Even fluids not normally associated with lubrication, such as water, kerosene or paraffin, may be used.

Lubrication improves the removal of heat from the bearing position and the formation of a hydrodynamic lubricating film has a very favourable effect on the wear behaviour of the bearing and considerably extends bearing life.

If periodic relubrication with grease is used to enhance sealing or to protect the counterface against corrosion, bearing life will also be extended. A single initial application of grease when mounting PTFE composite bearings may, however, have a negative influence on bearing life, as the grease will form a paste-like mixture with the wear particles produced during running in. This “paste” will increase bearing wear.

Age-resistant lithium base greases are preferred for operating temperatures up to 80 °C, while at higher temperatures, silicone greases should be used. Greases containing solid lubricants such as molybdenum disulphide are totally unsuitable.

POM composite bearings

POM composite dry sliding bearings require an initial application of grease on mounting. Relubrication is not required but the presence or constant supply of lubricating fluid or periodic grease relubrication serve to extend bearing life considerably.

For this reason POM composite bushings having a bore diameter of 10 mm and above and a width of 12 mm or more are supplied as standard with a lubrication hole (→ fig 1). The hole dimensions and position are in accordance with DIN 1434-3:1983. The same greases as those recommended above can be used.

Mounting

Skill and care in mounting are prerequisites for the successful performance of bearings and the avoidance of premature wear.

The counterface (shaft seating) and other components of the bearing arrangement should be carefully cleaned and deburred before mounting is begun. Unmachined surfaces in cast iron housings must be free of sand. The condition of the shaft should be carefully checked so that there are no sharp edges or burrs or surface defects which would damage the sliding surface of the bushings as they are mounted.

A mounting dolly is the most suitable tool for mounting PTFE composite and POM composite dry sliding

bushings and flanged bushings (→ **fig 1**). An O-section rubber ring placed on the dolly is a simple means of retaining the bushing in position. The use of a mounting ring (→ **fig 2**) is recommended for larger bushings as it aligns and centres the bushing so that it will not tilt or skew when being pressed in. A light oiling or greasing of the seating in the housing makes mounting easier. When mounting larger bushings it has been found that using a solid lubricant paste on the seating is beneficial in reducing the risk of fretting corrosion and also reducing the force required for mounting.

Composite dry sliding bushings and flanged bushings which are to be heavily loaded in operation should be

mounted so that the butt joint is at 90° to the loaded zone in operation (→ **fig 3**), otherwise life will be reduced. When mounting thrust washers care should be taken that they are correctly positioned, i.e. the steel backing should abut the housing wall.

If composite dry sliding bearings are to be located in the housing using adhesive, it should be remembered that the adhesive used should be suitable for the expected operating temperature and should have suitable expansion, ageing resistance, strength and curing properties. If no operational experience is available, it is recommended that the adhesive manufacturer be contacted for advice. When applying adhesive care must be taken to see that no adhesive reaches the sliding surface.

Mounting with a mandrel

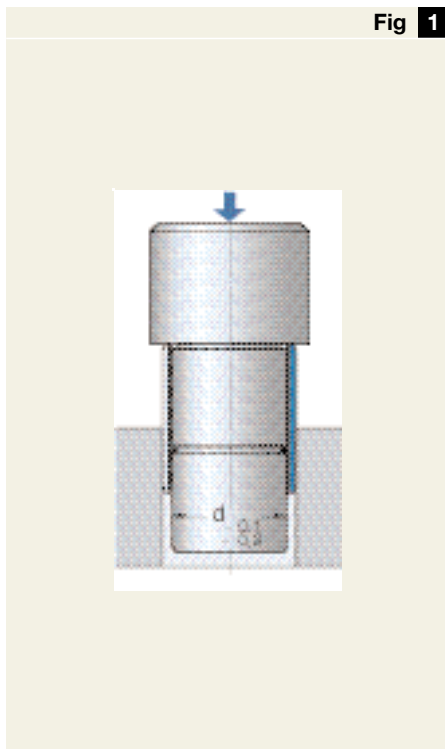

Mounting with a mandrel and mounting ring

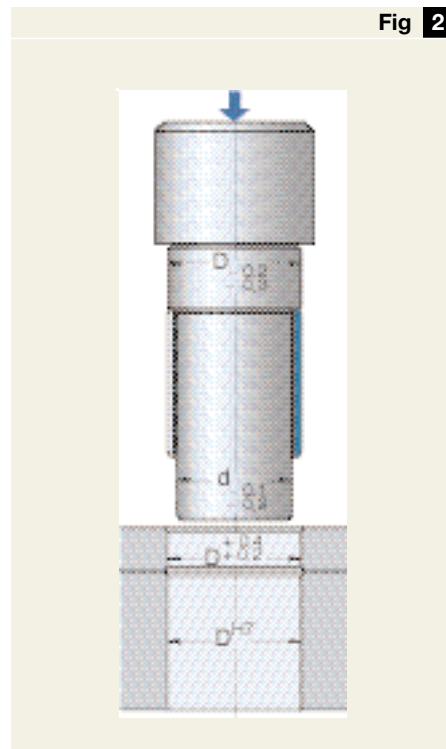

The main direction of the load must be at 90° to the plane of the butt joint

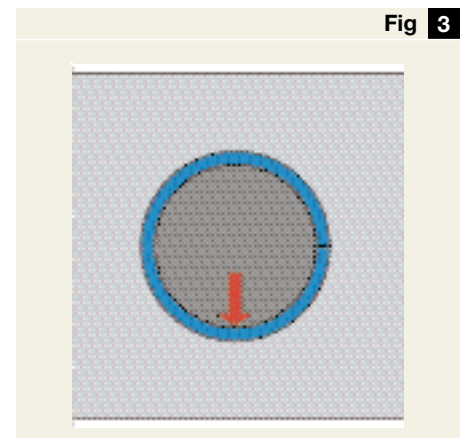

Bearing data – general

Dimensions

The dimensions of the metric sizes of PTFE composite and POM composite dry sliding bushings in the bore diameter range 4 to 160 mm, inclusive, are in accordance, with a few exceptions, with those specified in ISO 3547-1976 and DIN 1494/1:1983.

The dimensions of the inch-size bushings, the flanged bushings and the thrust washers have not been standardised.

Tolerances

Bushings: The tolerances for the outside diameter of the metric sizes of SKF PTFE composite and POM composite dry sliding bushings correspond to DIN 1494/1:1983. To check the values, the procedure given in DIN 1494/2:1983 should be used. For all sizes, the tolerances for the width B are a uniform $\pm 0,25$ mm.

Flanged bushings: For all sizes, when mounted, the tolerances are a uniform $\pm 0,5$ mm for the flange diameter D_1 and for the width B_1 $+0,05/-0,20$ mm.

Thrust washers: The tolerances for the diameters are given in the product table. The tolerances for the height are

- $0/-0,05$ mm for PTFE composite thrust washers
- $0/-0,10$ mm for POM composite thrust washers.

Strip: The tolerances for the height are

- $0/-0,05$ mm for PTFE composite strip
- $0/-0,10$ mm for POM composite strip

Operating clearance

The operating clearance of bushings depends on the recommended shaft and housing tolerances. Guideline values for bushings in metric sizes are

given in **Tables 1** and **3** and for inch-sized bushings in **Tables 2** and **4**.

Excessive clearance may have a negative influence on the service life of PTFE composite bushings if they are not lubricated.

Permissible operating temperature range

PTFE composite dry sliding bearings can be used at temperatures between -200 and $+250$ °C.

The operating temperature range for POM composite bearings is -40 to $+110$ °C, although brief periods of operation at $+130$ °C are permissible.

The service life of SKF composite dry sliding bearings will be shortened when operating at temperatures above a given value. This is taken into account when calculating the basic rating service life by the temperature factor c_3 (\rightarrow **Diagram 5**, **page 12**).

Running-in

During a short running-in phase there will be some transfer of material from the covering layer of bearings made from PTFE composite to the counterface. After this transfer has taken place, the characteristic low friction and wear properties of these bearings will be obtained.

Electrical properties

Bearings made from POM composite, because of their acetal resin covering layer, may act as electrical insulators when new. To avoid the build-up of static electricity, components at risk should be earthed.

Product designations

SKF metric composite dry sliding bearings are identified by designations made up of a prefix PCM which may have a fourth letter indicating the type of bearing (e.g. PCMW for a thrust

washer) followed by 6 to 9 figures giving the dimensions (d, D, B/H) in millimetres uncoded. The small bushings carrying the additional suffix /VB055 are an exception to this: the outside diameter is 0,5 mm larger than indicated in the designation. The actual material used is identified by a suffix: B for PTFE composite and M for POM composite. For example, PCM 081008 M is a POM composite bushing with $d = 8$ mm, $D = 10$ mm and $B = 8$ mm.

The inch-size bearings have similar designations, but in this case the prefix is PCZ and the size (d, B) is shown in 1/16ths of an inch, e.g. PCZ 1208 B is a PTFE composite bushing with $d = 12/16'' = 3/4''$ and $B = 8/16'' = 1/2''$.

Composite bushings with metric dimensions
d 3 – 12 mm

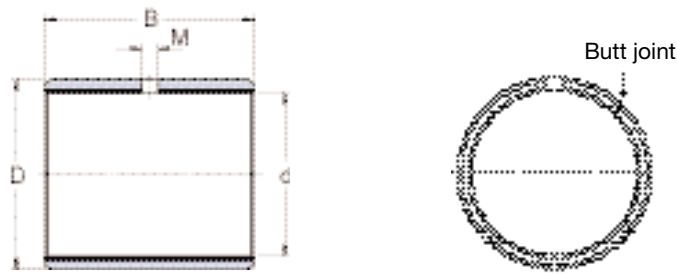

Dimensions				Basic load ratings		Mass	Designations PTFE composite	POM composite
d	D	B	M	C	C ₀			
mm				N		g	-	-
3	4,5	3	-	720	2 240	0,2	PCM 030403 B/VB055	-
	4,5	5	-	1 200	3 750	0,3	PCM 030405 B/VB055	-
	4,5	6	-	1 430	4 500	0,4	PCM 030406 B/VB055	-
4	5,5	3	-	965	3 000	0,2	PCM 040503 B/VB055	-
	5,5	4	-	1 270	4 000	0,3	PCM 040504 B/VB055	-
	5,5	6	-	1 930	6 000	0,6	PCM 040506 B/VB055	-
	5,5	10	-	3 200	10 000	0,8	PCM 040510 B/VB055	-
5	7	5	-	2 000	6 200	0,7	PCM 050705 B	-
	7	8	-	3 200	10 000	1,1	PCM 050708 B	-
	7	10	-	4 000	12 500	1,4	PCM 050710 B	-
6	8	6	-	2 900	9 000	1,0	PCM 060806 B	-
	8	8	-	3 800	12 000	1,3	PCM 060808 B	-
	8	10	-	4 800	15 000	1,6	PCM 060810 B	-
7	9	10	-	5 600	17 600	1,8	PCM 070910 B	-
8	10	6	-	3 800	12 000	1,2	PCM 081006 B	-
	10	8	-	5 100	16 000	1,7	PCM 081008 B	-
	10	8	-	7 650	16 000	1,3	-	PCM 081008 M
	10	10	-	6 400	20 000	2,1	PCM 081010 B	-
	10	10	-	9 650	20 000	1,6	-	PCM 081010 M
	10	12	-	7 650	24 000	2,5	PCM 081012 B	-
	10	12	-	11 600	24 000	1,9	-	PCM 081012 M
10	12	8	-	6 400	20 000	2,0	PCM 101208 B	-
	12	10	-	8 000	25 000	2,5	PCM 101210 B	-
	12	10	-	12 000	25 000	1,9	-	PCM 101210 M
	12	12	-	9 650	30 000	3,0	PCM 101212 B	-
	12	12	3	14 300	30 000	2,3	-	PCM 101212 M
	12	15	-	12 000	37 500	3,8	PCM 101215 B	-
	12	15	3	18 000	37 500	2,9	-	PCM 101215 M
	12	20	-	16 000	50 000	5,1	PCM 101220 B	-
	12	20	3	24 000	50 000	3,9	-	PCM 101220 M
	12	14	8	-	7 650	24 000	2,4	PCM 121408 B
14		10	-	9 650	30 000	3,0	PCM 121410 B	-
14		10	3	14 300	30 000	2,3	-	PCM 121410 M
14		12	-	11 600	36 000	3,6	PCM 121412 B	-
14		12	3	17 300	36 000	2,8	-	PCM 121412 M
14		15	-	14 300	45 000	4,5	PCM 121415 B	-
14		15	3	21 600	45 000	3,5	-	PCM 121415 M
14		20	-	19 300	60 000	6,0	PCM 121420 B	-
14		20	3	29 000	60 000	4,6	-	PCM 121420 M
14		25	-	24 000	75 000	7,6	PCM 121425 B	-
14		25	3	36 000	75 000	5,8	-	PCM 121425 M

Composite bushings with metric dimensions

d 13 – 32 mm

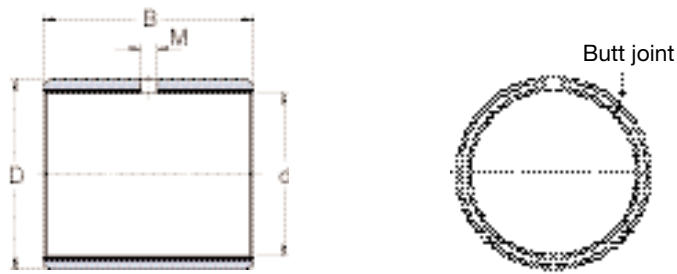

Dimensions				Basic load ratings		Mass	Designations	POM composite
d	D	B	M	dynamic	static			
				C	C ₀		PTFE composite	
mm				N		g	-	
13	15	10	-	10 400	32 500	3,2	PCM 131510 B	-
	15	10	3	15 600	32 500	2,4	-	PCM 131510 M
	15	20	-	20 800	65 500	6,3	PCM 131520 B	-
14	16	10	-	11 200	34 500	3,5	PCM 141610 B	-
	16	12	-	13 400	41 500	4,2	PCM 141612 B	-
	16	15	-	16 600	52 000	5,2	PCM 141615 B	-
	16	15	3	25 000	52 000	4,0	-	PCM 141615 M
	16	20	-	22 400	70 000	7,0	PCM 141620 B	-
	16	20	3	33 500	70 000	5,3	-	PCM 141620 M
	16	25	-	28 000	88 000	8,7	PCM 141625 B	-
	16	25	3	41 500	88 000	6,6	-	PCM 141625 M
	15	17	10	-	12 000	37 500	3,7	PCM 151710 B
17		10	3	18 000	37 500	2,8	-	PCM 151710 M
17		12	-	14 300	45 000	4,4	PCM 151712 B	-
17		12	3	21 600	45 000	3,4	-	PCM 151712 M
17		15	-	18 000	56 000	5,6	PCM 151715 B	-
17		15	3	27 000	56 000	4,3	-	PCM 151715 M
17		20	-	24 000	75 000	7,4	PCM 151720 B	-
17		25	-	30 000	93 000	9,3	PCM 151725 B	-
16		18	10	-	12 900	40 000	3,9	PCM 161810 B
	18	12	-	15 300	48 000	4,7	PCM 161812 B	-
	18	15	-	19 300	60 000	5,9	PCM 161815 B	-
	18	15	3	29 000	60 000	4,5	-	PCM 161815 M
	18	20	-	25 500	80 000	7,9	PCM 161820 B	-
	18	20	3	38 000	80 000	6,0	-	PCM 161820 M
	18	25	-	32 000	100 000	9,9	PCM 161825 B	-
	18	25	3	48 000	100 000	7,5	-	PCM 161825 M
	18	20	15	-	21 600	67 000	6,6	PCM 182015 B
20		15	3	32 500	67 000	5,0	-	PCM 182015 M
20		20	-	29 000	90 000	8,8	PCM 182020 B	-
20		20	3	43 000	90 000	6,7	-	PCM 182020 M
20		25	-	36 000	112 000	11	PCM 182025 B	-
20		25	3	54 000	112 000	8,4	-	PCM 182025 M

Dimensions				Basic load ratings		Mass	Designations	POM	
d	D	B	M	dynamic	static		PTFE composite	composite	
				C	C ₀				
mm				N		g	-		
20	23	10	-	14 600	45 500	7,4	PCM 202310 B	-	
	23	10	3	22 000	45 500	6,4	-	PCM 202310 M	
	23	15	-	22 800	71 000	11	PCM 202315 B	-	
	23	15	3	34 000	71 000	9,7	-	PCM 202315 M	
	23	20	-	30 500	96 500	15	PCM 202320 B	-	
	23	20	3	46 500	96 500	13	-	PCM 202320 M	
	23	25	-	39 000	120 000	19	PCM 202325 B	-	
	23	25	3	58 500	120 000	16	-	PCM 202325 M	
	23	30	-	46 500	146 000	23	PCM 202330 B	-	
	23	30	3	69 500	146 000	19	-	PCM 202330 M	
	22	25	15	-	25 000	78 000	12	PCM 222515 B	-
		25	15	3	37 500	78 000	11	-	PCM 222515 M
		25	20	-	34 000	106 000	16	PCM 222520 B	-
		25	20	3	51 000	106 000	14	-	PCM 222520 M
25		25	-	42 500	134 000	21	PCM 222525 B	-	
25		25	3	64 000	134 000	18	-	PCM 222525 M	
25		30	-	51 000	160 000	25	PCM 222530 B	-	
25		30	3	76 500	160 000	21	-	PCM 222530 M	
24		27	15	-	27 500	85 000	13	PCM 242715 B	-
		27	20	-	36 500	116 000	18	PCM 242720 B	-
	27	20	4	55 000	116 000	15	-	PCM 242720 M	
	27	25	-	46 500	146 000	22	PCM 242725 B	-	
	27	30	-	56 000	176 000	26	PCM 242730 B	-	
	25	28	15	-	28 500	88 000	14	PCM 252815 B	-
28		15	4	42 500	88 000	12	-	PCM 252815 M	
28		20	-	38 000	120 000	18	PCM 252820 B	-	
28		20	4	57 000	120 000	16	-	PCM 252820 M	
28		25	-	48 000	150 000	23	PCM 252825 B	-	
28		25	4	72 000	150 000	20	-	PCM 252825 M	
28		30	-	58 500	183 000	28	PCM 252830 B	-	
28		30	4	88 000	183 000	24	-	PCM 252830 M	
28		40	-	78 000	245 000	37	PCM 252840 B	-	
28		50	-	98 000	310 000	47	PCM 252850 B	-	
28		50	4	146 000	310 000	40	-	PCM 252850 M	
28		32	20	-	43 000	134 000	28	PCM 283220 B	-
		32	20	4	64 000	134 000	25	-	PCM 283220 M
		32	25	-	54 000	170 000	35	PCM 283225 B	-
	32	25	4	81 500	170 000	32	-	PCM 283225 M	
	32	30	-	65 500	204 000	42	PCM 283230 B	-	
	32	30	4	98 000	204 000	38	-	PCM 283230 M	
30	34	15	-	34 000	106 000	22	PCM 303415 B	-	
	34	20	-	46 500	143 000	30	PCM 303420 B	-	
	34	20	4	69 500	143 000	27	-	PCM 303420 M	
	34	25	-	58 500	180 000	37	PCM 303425 B	-	
	34	30	-	69 500	220 000	45	PCM 303430 B	-	
	34	30	4	106 000	220 000	41	-	PCM 303430 M	
	34	40	-	95 000	300 000	60	PCM 303440 B	-	
	34	40	4	140 000	300 000	54	-	PCM 303440 M	
32	36	20	-	49 000	153 000	31	PCM 323620 B	-	
	36	20	4	73 500	153 000	29	-	PCM 323620 M	
	36	30	-	75 000	232 000	48	PCM 323630 B	-	
	36	30	4	112 000	232 000	43	-	PCM 323630 M	
	36	40	-	100 000	315 000	64	PCM 323640 B	-	
	36	40	4	150 000	315 000	57	-	PCM 323640 M	

Composite bushings with metric dimensions

d 35 – 95 mm

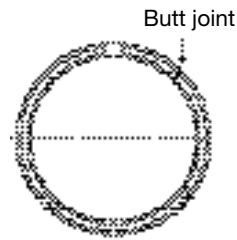
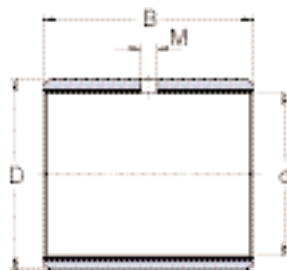

Dimensions				Basic load ratings		Mass	Designations PTFE composite	POM composite	
d	D	B	M	dynamic C	static C ₀				
mm				N		g	-	-	
35	39	20	-	54 000	166 000	34	PCM 353920 B	-	
	39	20	4	80 000	166 000	31	-	PCM 353920 M	
	39	30	-	81 500	255 000	52	PCM 353930 B	-	
	39	30	4	122 000	255 000	47	-	PCM 353930 M	
	39	40	-	110 000	345 000	68	PCM 353940 B	-	
	39	50	-	137 000	430 000	87	PCM 353950 B	-	
	39	50	4	208 000	430 000	78	-	PCM 353950 M	
	37	40	20	-	57 000	176 000	27	PCM 374020 B	-
		40	20	4	85 000	176 000	23	-	PCM 374020 M
40		30	4	129 000	270 000	35	-	PCM 374030 M	
40	44	20	-	61 000	193 000	39	PCM 404420 B	-	
	44	20	4	91 500	193 000	36	-	PCM 404420 M	
	44	30	-	93 000	290 000	59	PCM 404430 B	-	
	44	30	4	140 000	290 000	53	-	PCM 404430 M	
	44	40	-	125 000	390 000	78	PCM 404440 B	-	
	44	40	4	190 000	390 000	66	-	PCM 404440 M	
	44	50	-	156 000	490 000	98	PCM 404450 B	-	
	44	50	4	236 000	490 000	89	-	PCM 404450 M	
45	50	20	-	69 500	216 000	65	PCM 455020 B	-	
	50	20	5	104 000	216 000	52	-	PCM 455020 M	
	50	30	-	106 000	325 000	83	PCM 455030 B	-	
	50	30	5	156 000	325 000	78	-	PCM 455030 M	
	50	40	-	140 000	440 000	110	PCM 455040 B	-	
	50	40	5	212 000	440 000	105	-	PCM 455040 M	
	50	50	-	176 000	550 000	140	PCM 455050 B	-	
	50	50	5	265 000	550 000	130	-	PCM 455050 M	
	50	55	20	-	76 500	240 000	62	PCM 505520 B	-
55		30	-	116 000	365 000	93	PCM 505530 B	-	
55		30	5	176 000	365 000	86	-	PCM 505530 M	
55		40	-	156 000	490 000	125	PCM 505540 B	-	
55		40	5	236 000	490 000	115	-	PCM 505540 M	
55		60	-	236 000	735 000	185	PCM 505560 B	-	
55		60	5	355 000	735 000	170	-	PCM 505560 M	

Dimensions				Basic load ratings		Mass	Designations PTFE composite	POM composite	
d	D	B	M	dynamic C	static C ₀				
mm				N		g	-		
55	60	20	-	85 000	265 000	67	PCM 556020 B	-	
	60	20	6	127 000	265 000	63	-	PCM 556020 M	
	60	25	-	106 000	335 000	84	PCM 556025 B	-	
	60	25	6	160 000	335 000	78	-	PCM 556025 M	
	60	30	-	129 000	400 000	100	PCM 556030 B	-	
	60	30	6	193 000	400 000	94	-	PCM 556030 M	
	60	40	-	173 000	540 000	135	PCM 556040 B	-	
	60	40	6	260 000	540 000	125	-	PCM 556040 M	
	60	50	-	216 000	680 000	170	PCM 556050 B	-	
	60	50	6	325 000	680 000	155	-	PCM 556050 M	
	60	60	-	260 000	815 000	200	PCM 556060 B	-	
	60	65	20	-	91 500	290 000	75	PCM 606520 B	-
65		30	-	140 000	440 000	110	PCM 606530 B	-	
65		30	6	212 000	440 000	100	-	PCM 606530 M	
65		40	-	190 000	585 000	145	PCM 606540 B	-	
65		40	6	280 000	585 000	135	-	PCM 606540 M	
65		60	-	285 000	880 000	220	PCM 606560 B	-	
65		60	6	425 000	880 000	205	-	PCM 606560 M	
65		70	-	335 000	1 040 000	255	PCM 606570 B	-	
65		70	6	500 000	1 040 000	240	-	PCM 606570 M	
65		70	30	-	153 000	475 000	120	PCM 657030 B	-
		70	50	-	255 000	800 000	200	PCM 657050 B	-
		70	50	6	380 000	800 000	185	-	PCM 657050 M
	70	70	-	360 000	1 120 000	275	PCM 657070 B	-	
	70	70	6	540 000	1 120 000	255	-	PCM 657070 M	
70	75	40	-	220 000	680 000	170	PCM 707540 B	-	
	75	50	-	275 000	865 000	210	PCM 707550 B	-	
	75	50	6	415 000	865 000	195	-	PCM 707550 M	
	75	70	-	390 000	1 220 000	300	PCM 707570 B	-	
	75	70	6	585 000	1 220 000	275	-	PCM 707570 M	
75	80	40	6	355 000	735 000	170	-	PCM 758040 M	
	80	50	-	300 000	930 000	230	PCM 758050 B	-	
	80	60	-	355 000	1 100 000	270	PCM 758060 B	-	
	80	60	6	530 000	1 100 000	255	-	PCM 758060 M	
	80	80	-	475 000	1 500 000	365	PCM 758080 B	-	
	80	80	6	710 000	1 500 000	340	-	PCM 758080 M	
80	85	40	6	375 000	780 000	180	-	PCM 808540 M	
	85	60	-	375 000	1 180 000	290	PCM 808560 B	-	
	85	60	6	560 000	1 180 000	270	-	PCM 808560 M	
	85	80	6	750 000	1 560 000	360	-	PCM 808580 M	
	85	100	-	630 000	1 960 000	485	PCM 8085100 B	-	
	85	100	6	950 000	1 960 000	450	-	PCM 8085100 M	
85	90	30	-	196 000	610 000	150	PCM 859030 B	-	
	90	30	6	290 000	610 000	145	-	PCM 859030 M	
	90	60	-	400 000	1 250 000	305	PCM 859060 B	-	
	90	60	6	600 000	1 250 000	285	-	PCM 859060 M	
	90	100	-	670 000	2 080 000	510	PCM 8590100 B	-	
	90	100	6	1 000 000	2 080 000	475	-	PCM 8590100 M	
90	95	60	-	425 000	1 320 000	325	PCM 909560 B	-	
	95	60	6	640 000	1 320 000	300	-	PCM 909560 M	
	95	100	-	710 000	2 240 000	540	PCM 9095100 B	-	
	95	100	6	1 060 000	2 240 000	505	-	PCM 9095100 M	
95	100	30	6	325 000	680 000	160	-	PCM 9510030 M	
	100	60	-	450 000	1 400 000	340	PCM 9510060 B	-	
	100	60	6	670 000	1 400 000	320	-	PCM 9510060 M	
	100	100	-	750 000	2 360 000	570	PCM 95100100 B	-	
	100	100	6	1 120 000	2 360 000	530	-	PCM 95100100 M	

Composite bushings with metric dimensions

d 100 – 300 mm

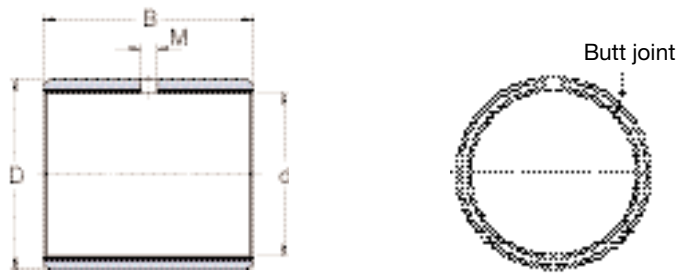

Dimensions				Basic load ratings		Mass	Designations PTFE composite	POM composite	
d	D	B	M	C	C ₀				
mm				N		g	-		
100	105	30	6	345 000	720 000	170	-	PCM 10010530 M	
	105	50	-	390 000	1 220 000	305	PCM 10010550 B	-	
	105	50	6	585 000	1 220 000	280	-	PCM 10010550 M	
	105	60	-	475 000	1 460 000	360	PCM 10010560 B	-	
	105	60	6	710 000	1 460 000	335	-	PCM 10010560 M	
	105	80	6	950 000	1 960 000	445	-	PCM 10010580 M	
	105	115	-	915 000	2 850 000	690	PCM 100105115 B	-	
	105	115	6	1 370 000	2 850 000	640	-	PCM 100105115 M	
	105	110	60	-	490 000	1 530 000	375	PCM 10511060 B	-
		110	60	8	735 000	1 530 000	350	-	PCM 10511060 M
110		115	-	950 000	3 000 000	725	PCM 105110115 B	-	
110		115	8	1 430 000	3 000 000	675	-	PCM 105110115 M	
110	115	50	8	640 000	1 340 000	305	-	PCM 11011550 M	
	115	60	-	520 000	1 630 000	395	PCM 11011560 B	-	
	115	60	8	780 000	1 630 000	370	-	PCM 11011560 M	
	115	115	-	1 000 000	3 150 000	760	PCM 110115115 B	-	
	115	115	8	1 500 000	3 150 000	705	-	PCM 110115115 M	
115	120	50	-	450 000	1 400 000	340	PCM 11512050 B	-	
	120	50	8	670 000	1 400 000	320	-	PCM 11512050 M	
	120	70	-	630 000	1 960 000	480	PCM 11512070 B	-	
	120	70	8	950 000	1 960 000	450	-	PCM 11512070 M	
120	125	60	-	560 000	1 760 000	430	PCM 12012560 B	-	
	125	60	8	850 000	1 760 000	400	-	PCM 12012560 M	
	125	100	-	950 000	3 000 000	715	PCM 120125100 B	-	
	125	100	8	1 430 000	3 000 000	665	-	PCM 120125100 M	
	125	120	-	1 140 000	3 550 000	880	PCM 120125120 B	-	
125	130	100	-	980 000	3 100 000	745	PCM 125130100 B	-	
	130	100	8	1 500 000	3 100 000	695	-	PCM 125130100 M	
130	135	60	-	610 000	1 900 000	465	PCM 13013560 B	-	
	135	60	8	915 000	1 900 000	435	-	PCM 13013560 M	
	135	100	-	1 020 000	3 200 000	775	PCM 130135100 B	-	
	135	100	8	1 530 000	3 200 000	720	-	PCM 130135100 M	
135	140	60	-	640 000	2 000 000	480	PCM 13514060 B	-	
	140	60	8	950 000	2 000 000	450	-	PCM 13514060 M	
	140	80	-	850 000	2 650 000	645	PCM 13514080 B	-	
	140	80	8	1 270 000	2 650 000	600	-	PCM 13514080 M	
140	145	60	-	655 000	2 040 000	500	PCM 14014560 B	-	
	145	60	8	980 000	2 040 000	465	-	PCM 14014560 M	
	145	100	-	1 100 000	3 450 000	835	PCM 140145100 B	-	
	145	100	8	1 660 000	3 450 000	775	-	PCM 140145100 M	
	145	120	-	1 340 000	4 150 000	1 000	PCM 140145120 B	-	

Dimensions				Basic load ratings		Mass	Designations PTFE composite	POM composite
d	D	B	M	dynamic C	static C ₀			
mm				N		g	-	
150	155	60	-	710 000	2 200 000	535	PCM 15015560 B	-
	155	60	8	1 060 000	2 200 000	500	-	PCM 15015560 M
	155	80	-	950 000	3 000 000	715	PCM 15015580 B	-
	155	80	8	1 430 000	3 000 000	665	-	PCM 15015580 M
	155	100	-	1 200 000	3 750 000	890	PCM 150155100 B	-
	155	100	8	1 800 000	3 750 000	830	-	PCM 150155100 M
160	165	80	-	1 000 000	3 150 000	780	PCM 16016580 B	-
	165	80	8	1 500 000	3 150 000	710	-	PCM 16016580 M
	165	100	-	1 270 000	3 900 000	970	PCM 160165100 B	-
	165	100	8	1 900 000	3 900 000	885	-	PCM 160165100 M
180	185	80	-	1 140 000	3 550 000	870	PCM 18018580 B	-
	185	80	8	1 700 000	3 550 000	795	-	PCM 18018580 M
	185	100	-	1 430 000	4 400 000	1 100	PCM 180185100 B	-
	185	100	8	2 120 000	4 400 000	995	-	PCM 180185100 M
190	195	60	8	1 340 000	2 800 000	630	-	PCM 19019560 M
	195	100	8	2 240 000	4 650 000	1 050	-	PCM 190195100 M
200	205	100	-	1 600 000	4 900 000	1 200	PCM 200205100 B	-
	205	100	8	2 360 000	4 900 000	1 100	-	PCM 200205100 M
210	215	100	-	1 660 000	5 200 000	1 250	PCM 210215100 B	-
	215	100	8	2 500 000	5 200 000	1 150	-	PCM 210215100 M
220	225	100	-	1 730 000	5 400 000	1 350	PCM 220225100 B	-
	225	100	8	2 600 000	5 400 000	1 200	-	PCM 220225100 M
250	255	100	-	1 960 000	6 100 000	1 500	PCM 250255100 B	-
	255	100	8	3 000 000	6 100 000	1 400	-	PCM 250255100 M
280	285	80	-	1 760 000	5 500 000	1 350	PCM 28028580 B	-
	285	80	8	2 650 000	5 500 000	1 250	-	PCM 28028580 M
300	305	50	-	1 180 000	3 650 000	900	PCM 30030550 B	-
	305	50	8	1 760 000	3 650 000	825	-	PCM 30030550 M
	305	100	-	2 360 000	7 350 000	1 800	PCM 300305100 B	-
	305	100	8	3 550 000	7 350 000	1 650	-	PCM 300305100 M

Composite bushings with inch dimensions
d 0,125 – 1,75 inch

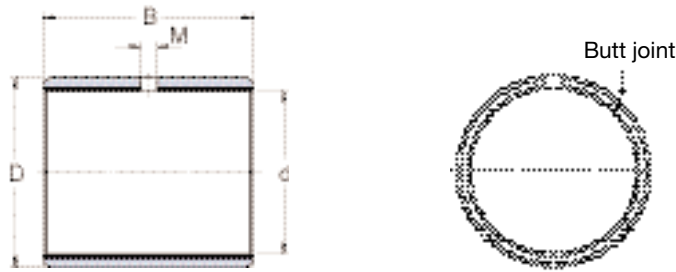

Dimensions						Basic load ratings		Mass	Designations		
d	D	B	M	C	C ₀	dynamic	static		PTFE composite	POM composite	
inch	mm	inch	mm	mm	N			g	-		
0,125	3,175	0,1875	4,763	0,125	3,175	-	800	2 500	0,23	PCZ 0202 B	-
				0,1875	4,763	-	1 200	3 750	0,34	PCZ 0203 B	-
0,1562	3,969	0,2188	5,556	0,1562	3,969	-	1 270	3 900	0,34	PCZ 025025 B	-
				0,25	6,35	-	2 000	6 300	0,54	PCZ 02504 B	-
0,1875	4,763	0,25	6,35	0,1875	4,763	-	1 800	5 700	0,48	PCZ 0303 B	-
				0,25	6,35	-	2 400	7 500	0,63	PCZ 0304 B	-
				0,375	9,525	-	3 650	11 400	0,95	PCZ 0306 B	-
0,25	6,35	0,3125	7,938	0,25	6,35	-	3 250	10 000	0,81	PCZ 0404 B	-
				0,375	9,525	-	4 800	15 000	1,2	PCZ 0406 B	-
0,3125	7,938	0,375	9,525	0,375	9,525	-	6 000	19 000	1,5	PCZ 0506 B	-
				0,5	12,7	-	8 000	25 000	2,0	PCZ 0508 B	-
0,375	9,525	0,4687	11,906	0,375	9,525	-	7 200	22 800	2,8	PCZ 0606 B	-
				0,375	9,525	-	10 800	22 800	2,3	-	PCZ 0606 M
				0,5	12,7	-	9 800	30 000	3,8	PCZ 0608 B	-
				0,5	12,7	-	11 400	30 000	3,0	-	PCZ 0608 M
				0,75	19,05	-	14 600	45 500	5,8	PCZ 0612 B	-
				0,75	19,05	-	21 600	45 500	4,6	-	PCZ 0612 M
0,4375	11,113	0,5312	13,494	0,5	12,7	-	11 200	35 500	4,3	PCZ 0708 B	-
				0,5	12,7	3	17 000	35 500	3,5	-	PCZ 0708 M
				0,75	19,05	-	17 000	53 000	6,5	PCZ 0712 B	-
				0,75	19,05	3	25 500	53 000	5,2	-	PCZ 0712 M
0,5	12,7	0,5937	15,081	0,375	9,525	-	9 800	30 000	3,7	PCZ 0806 B	-
				0,375	9,525	3	14 600	30 000	3,0	-	PCZ 0806 M
				0,5	12,7	-	12 900	40 500	4,9	PCZ 0808 B	-
				0,5	12,7	3	19 300	40 500	3,9	-	PCZ 0808 M
				0,625	15,875	-	16 000	50 000	6,1	PCZ 0810 B	-
				0,625	15,875	3	24 000	50 000	4,9	-	PCZ 0810 M
				0,875	22,225	-	22 400	71 000	8,5	PCZ 0814 B	-
0,875	22,225	3	33 400	71 000	6,9	-	PCZ 0814 M				
0,5625	14,288	0,6562	16,669	0,5	12,7	-	14 600	45 500	5,4	PCZ 0908 B	-
				0,5	12,7	3	21 600	45 500	4,4	-	PCZ 0908 M
				0,75	19,05	-	21 600	68 000	8,2	PCZ 0912 B	-
				0,75	19,05	3	32 500	68 000	6,6	-	PCZ 0912 M
0,625	15,875	0,7187	18,256	0,5	12,7	-	16 000	50 000	6,0	PCZ 1008 B	-
				0,5	12,7	3	24 000	50 000	4,9	-	PCZ 1008 M
				0,625	15,875	-	20 000	63 000	7,5	PCZ 1010 B	-
				0,625	15,875	3	30 000	63 000	6,1	-	PCZ 1010 M
				0,75	19,05	-	24 000	75 000	9,0	PCZ 1012 B	-
				0,75	19,05	3	36 000	75 000	7,3	-	PCZ 1012 M
				0,875	22,225	-	28 000	88 000	10,5	PCZ 1014 B	-
				0,875	22,225	3	42 500	88 000	8,5	-	PCZ 1014 M

Dimensions							Basic load ratings		Mass	Designations	POM
d		D		B		M	dynamic	static		PTFE composite	composite
inch	mm	inch	mm	inch	mm	mm	C	C ₀	g	-	
0,6875	17,463	0,7812	19,844	0,875	22,225	-	31 000	96 500	11	PCZ 1114 B	-
				0,875	22,225	3	46 500	96 500	9,3	-	PCZ 1114 M
0,75	19,05	0,875	22,225	0,5	12,7	-	18 300	56 000	9,8	PCZ 1208 B	-
				0,5	12,7	3	27 000	56 000	8,4	-	PCZ 1208 M
				0,75	19,05	-	28 000	86 500	15	PCZ 1212 B	-
				0,75	19,05	3	41 500	86 500	13	-	PCZ 1212 M
				1	25,4	-	37 500	118 000	20	PCZ 1216 B	-
0,875	22,225	1	25,4	1	25,4	3	56 000	118 000	17	-	PCZ 1216 M
				0,75	19,05	-	32 500	102 000	17	PCZ 1412 B	-
				0,75	19,05	4	49 000	102 000	15	-	PCZ 1412 M
				0,875	22,225	-	38 000	120 000	20	PCZ 1414 B	-
				0,875	22,225	4	57 000	120 000	17	-	PCZ 1414 M
1	25,4	1,125	28,575	1	25,4	-	44 000	137 000	23	PCZ 1416 B	-
				1	25,4	4	65 500	137 000	19	-	PCZ 1416 M
				0,75	19,05	-	37 500	116 000	19	PCZ 1612 B	-
				0,75	19,05	4	56 000	116 000	17	-	PCZ 1612 M
				1	25,4	-	50 000	156 000	26	PCZ 1616 B	-
1,125	28,575	1,2812	32,544	1	25,4	4	75 000	156 000	22	-	PCZ 1616 M
				1,5	38,1	-	76 500	236 000	38	PCZ 1624 B	-
				1,5	38,1	4	113 700	236 000	33	-	PCZ 1624 M
				0,75	19,05	-	41 500	129 000	27	PCZ 1812 B	-
				0,75	19,05	4	63 000	129 000	24	-	PCZ 1812 M
1,25	31,75	1,4062	35,719	1	25,4	-	56 000	176 000	36	PCZ 1816 B	-
				1	25,4	4	85 000	176 000	32	-	PCZ 1816 M
				0,75	19,05	-	46 500	146 000	30	PCZ 2012 B	-
				0,75	19,05	4	69 500	146 000	27	-	PCZ 2012 M
				1	25,4	-	64 000	196 000	40	PCZ 2016 B	-
1,375	34,925	1,5312	38,894	1	25,4	4	93 000	196 000	36	-	PCZ 2016 M
				1	25,4	4	93 000	196 000	36	-	PCZ 2016 M
				1,25	31,75	-	78 000	245 000	50	PCZ 2020 B	-
				1,25	31,75	4	118 000	245 000	45	-	PCZ 2020 M
				1,75	44,45	-	110 000	345 000	71	PCZ 2028 B	-
1,5	38,1	1,6562	42,069	1,75	44,45	4	166 000	345 000	63	-	PCZ 2028 M
				1	25,4	-	68 000	216 000	44	PCZ 2216 B	-
				1	25,4	4	104 000	216 000	39	-	PCZ 2216 M
				1,375	34,925	-	95 000	300 000	61	PCZ 2222 B	-
				1,375	34,925	4	143 000	300 000	54	-	PCZ 2222 M
1,625	41,275	1,7812	45,244	1,75	44,45	-	122 000	380 000	77	PCZ 2228 B	-
				1,75	44,45	4	183 000	380 000	69	-	PCZ 2228 M
				1	25,4	-	81 500	255 000	53	PCZ 2616 B	-
				1	25,4	5	122 000	255 000	46	-	PCZ 2616 M
				1,5	38,1	-	122 000	380 000	78	PCZ 2624 B	-
1,75	44,45	1,9375	49,213	1,5	38,1	5	186 000	380 000	69	-	PCZ 2624 M
				1	25,4	-	88 000	275 000	68	PCZ 2816 B	-
				1	25,4	5	132 000	275 000	61	-	PCZ 2816 M
				1,5	38,1	-	132 000	415 000	100	PCZ 2824 B	-
				1,5	38,1	5	200 000	415 000	92	-	PCZ 2824 M
1,75	44,45	1,9375	49,213	1,75	44,45	-	156 000	490 000	120	PCZ 2828 B	-
				1,75	44,45	5	232 000	490 000	110	-	PCZ 2828 M
				2	50,8	-	180 000	560 000	140	PCZ 2832 B	-
				2	50,8	5	265 000	560 000	130	-	PCZ 2832 M

Composite bushings with inch dimensions
d 1,875 – 7 inch

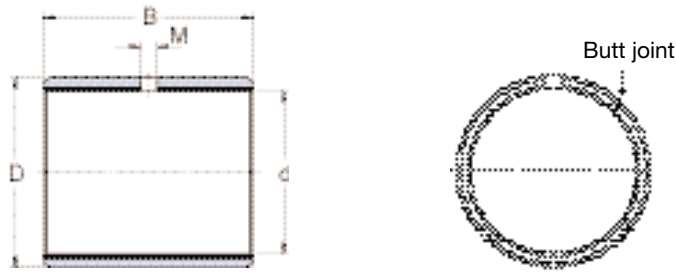

Dimensions						Basic load ratings		Mass	Designations		
d	D		B	M	C	static	PTFE composite		POM composite		
inch	mm	inch	mm	inch	mm	mm	N	g	-		
1,875	47,625	2,0625	52,388	1	25,4	-	93 000	290 000	72	PCZ 3016 B	-
				1	25,4	5	140 000	290 000	66	-	PCZ 3016 M
				1,875	47,625	-	180 000	560 000	135	PCZ 3030 B	-
				1,875	47,625	5	270 000	560 000	125	-	PCZ 3030 M
				2,25	57,15	-	216 000	670 000	160	PCZ 3036 B	-
				2,25	57,15	5	320 000	670 000	145	-	PCZ 3036 M
2	50,8	2,1875	55,563	1	25,4	-	100 000	310 000	77	PCZ 3216 B	-
				1	25,4	6	150 000	310 000	70	-	PCZ 3216 M
				1,5	38,1	-	153 000	475 000	115	PCZ 3224 B	-
				1,5	38,1	6	228 000	475 000	105	-	PCZ 3224 M
				2	50,8	-	204 000	640 000	155	PCZ 3232 B	-
				2	50,8	6	305 000	640 000	140	-	PCZ 3232 M
				2,5	63,5	-	255 000	800 000	190	PCZ 3240 B	-
				2,5	63,5	6	380 000	800 000	175	-	PCZ 3240 M
2,25	57,15	2,4375	61,913	2	50,8	-	228 000	710 000	170	PCZ 3632 B	-
				2	50,8	6	345 000	710 000	155	-	PCZ 3632 M
				2,25	57,15	-	260 000	800 000	195	PCZ 3636 B	-
				2,25	57,15	6	390 000	800 000	175	-	PCZ 3636 M
				2,5	63,5	-	285 000	900 000	215	PCZ 3640 B	-
				2,5	63,5	6	430 000	900 000	195	-	PCZ 3640 M
				3	76,2	-	345 000	1 080 000	250	PCZ 3648 B	-
2,5	63,5	2,6875	68,263	2	50,8	-	255 000	800 000	190	PCZ 4032 B	-
				2	50,8	6	380 000	800 000	175	-	PCZ 4032 M
				2,5	63,5	-	320 000	1 000 000	240	PCZ 4040 B	-
				2,5	63,5	6	480 000	1 000 000	215	-	PCZ 4040 M
				3	76,2	-	380 000	1 200 000	285	PCZ 4048 B	-
				3,5	88,9	-	450 000	1 400 000	335	PCZ 4056 B	-
2,75	69,85	2,9375	74,613	2	50,8	-	280 000	880 000	210	PCZ 4432 B	-
				2	50,8	6	415 000	880 000	190	-	PCZ 4432 M
				2,5	63,5	-	355 000	1 100 000	260	PCZ 4440 B	-
				2,5	63,5	6	530 000	1 100 000	235	-	PCZ 4440 M
				3	76,2	-	425 000	1 320 000	315	PCZ 4448 B	-
				3	76,2	6	630 000	1 320 000	285	-	PCZ 4448 M
				3,5	88,9	-	490 000	1 530 000	365	PCZ 4456 B	-
				3,5	88,9	6	735 000	1 530 000	330	-	PCZ 4456 M
3	76,2	3,1875	80,963	2	50,8	-	305 000	950 000	225	PCZ 4832 B	-
				2	50,8	6	455 000	950 000	205	-	PCZ 4832 M
				3	76,2	-	455 000	1 430 000	340	PCZ 4848 B	-
				3	76,2	6	695 000	1 430 000	310	-	PCZ 4848 M
				3,75	95,25	-	570 000	1 800 000	425	PCZ 4860 B	-
				3,75	95,25	6	865 000	1 800 000	385	-	PCZ 4860 M

Dimensions							Basic load ratings		Mass	Designations		
d		D		B		M	dynamic	static		PTFE composite	POM composite	
inch	mm	inch	mm	inch	mm	mm	C	C ₀	g	-		
3,5	88,9	3,6875	93,663	2,5	63,5	-	440 000	1 370 000	330	PCZ 5640 B	-	
				2,5	63,5	6	670 000	1 370 000	300	-	PCZ 5640 M	
				3	76,2	-	530 000	1 660 000	395	PCZ 5648 B	-	PCZ 5648 M
				3	76,2	6	800 000	1 660 000	360	-	PCZ 5648 M	
				3,75	95,25	-	670 000	2 080 000	495	PCZ 5660 B	-	PCZ 5660 M
				3,75	95,25	6	1 000 000	2 080 000	450	-	PCZ 5660 M	
4	101,6	4,1875	106,363	3	76,2	-	610 000	1 900 000	450	PCZ 6448 B	-	
				3	76,2	8	915 000	1 900 000	410	-	PCZ 6448 M	
				3,75	95,25	-	765 000	2 400 000	565	PCZ 6460 B	-	PCZ 6460 M
				3,75	95,25	8	1 140 000	2 400 000	510	-	PCZ 6460 M	
				4,75	120,65	-	965 000	3 050 000	715	PCZ 6476 B	-	PCZ 6476 M
				4,75	120,65	8	1 460 000	3 050 000	645	-	PCZ 6476 M	
5	127	5,1875	131,763	3	76,2	-	765 000	2 400 000	560	PCZ 8048 B	-	
				3,75	95,25	-	950 000	3 000 000	700	PCZ 8060 B	-	
6	152,4	6,1875	157,163	3	76,2	-	915 000	2 850 000	670	PCZ 9648 B	-	
				3,75	95,25	-	1 146 000	3 600 000	840	PCZ 9660 B	-	
7	177,8	7,1875	182,563	3,75	95,25	-	1 340 000	4 150 000	975	PCZ 11260 B	-	

Composite flanged bushings

d 6 – 35 mm

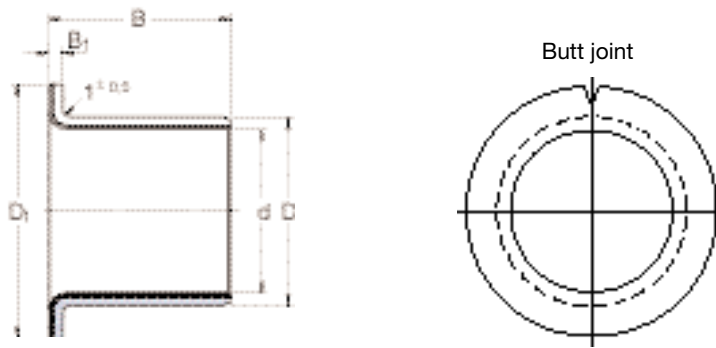

Dimensions					Basic load ratings				Mass	Designation
d	D	B	D ₁	B ₁	radial dynamic C	static C ₀	axial dynamic C _a	static C _{0a}	g	PTFE composite
mm					N				g	-
6	8	4	12	1	965	3 000	2 750	8 650	1,3	PCMF 060804 B
	8	8	12	1	2 900	9 000	2 750	8 650	1,9	PCMF 060808 B
8	10	5,5	15	1	2 240	6 950	5 100	16 000	2,1	PCMF 081005.5 B
	10	7,5	15	1	3 550	11 000	5 100	16 000	2,5	PCMF 081007.5 B
	10	9,5	15	1	4 800	15 000	5 100	16 000	2,9	PCMF 081009.5 B
10	12	7	18	1	4 000	12 500	8 000	25 000	3,1	PCMF 101207 B
	12	9	18	1	5 600	17 600	8 000	25 000	3,6	PCMF 101209 B
	12	12	18	1	8 000	25 000	8 000	25 000	4,3	PCMF 101212 B
	12	17	18	1	12 000	37 500	8 000	25 000	5,6	PCMF 101217 B
12	14	7	20	1	4 800	15 000	9 150	28 500	3,6	PCMF 121407 B
	14	9	20	1	6 700	20 800	9 150	28 500	4,2	PCMF 121409 B
	14	12	20	1	9 650	30 000	9 150	28 500	5,1	PCMF 121412 B
	14	15	20	1	12 500	39 000	9 150	28 500	6,1	PCMF 121415 B
	14	17	20	1	14 300	45 000	9 150	28 500	6,6	PCMF 121417 B
14	16	12	22	1	11 000	34 500	10 000	31 500	5,8	PCMF 141612 B
	16	17	22	1	16 600	52 000	10 000	31 500	7,5	PCMF 141617 B
15	17	9	23	1	8 300	26 000	10 400	32 500	5,1	PCMF 151709 B
	17	12	23	1	12 000	37 500	10 400	32 500	6,2	PCMF 151712 B
	17	17	23	1	18 000	56 000	10 400	32 500	7,6	PCMF 151717 B
16	18	12	24	1	12 200	38 000	8 500	26 500	6,2	PCMF 161812 B
	18	17	24	1	18 600	58 500	8 500	26 500	8,1	PCMF 161817 B
18	20	12	26	1	13 700	42 500	9 300	29 000	7,3	PCMF 182012 B
	20	17	26	1	20 800	65 500	9 300	29 000	9,5	PCMF 182017 B
	20	22	26	1	28 000	88 000	9 300	29 000	12	PCMF 182022 B
20	23	11,5	30	1,5	14 300	45 000	17 300	54 000	13	PCMF 202311.5 B
	23	15	30	1,5	20 000	62 000	17 300	54 000	16	PCMF 202315 B
	23	16,5	30	1,5	22 000	69 500	17 300	54 000	17	PCMF 202316.5 B
	23	21,5	30	1,5	30 500	95 000	17 300	54 000	21	PCMF 202321.5 B
25	28	11,5	35	1,5	17 300	54 000	20 400	64 000	16	PCMF 252811.5 B
	28	16,5	35	1,5	28 000	85 000	20 400	64 000	21	PCMF 252816.5 B
	28	21,5	35	1,5	37 500	116 000	20 400	64 000	25	PCMF 252821.5 B
30	34	16	42	2	30 500	95 000	29 000	91 500	35	PCMF 303416 B
	34	26	42	2	54 000	170 000	29 000	91 500	50	PCMF 303426 B
35	39	16	47	2	35 500	110 000	33 500	104 000	43	PCMF 353916 B
	39	26	47	2	63 000	196 000	33 500	104 000	61	PCMF 353926 B

Composite thrust washers
d 12 – 52 mm

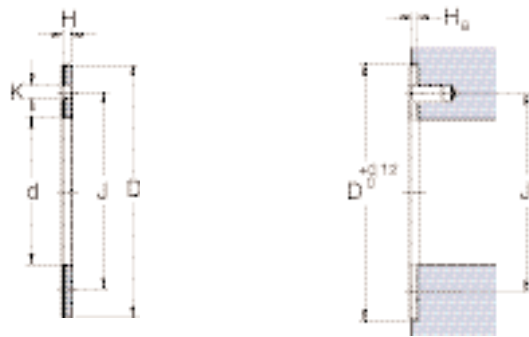

Dimensions						Basic load ratings		Mass	Designations PTFE composite	POM composite
d	D	H	J	K	H _a	C	C ₀			
mm						N		g	–	
12	24	1,5	18	1,75	1	28 000	85 000	3,8	PCMW 122401.5 B	–
	24	1,5	18	1,75	1	40 500	85 000	3,2	–	PCMW 122401.5 M
14	26	1,5	20	2,25	1	30 000	93 000	4,2	PCMW 142601.5 B	–
	26	1,5	20	2,25	1	45 000	93 000	3,6	–	PCMW 142601.5 M
18	32	1,5	25	2,25	1	44 000	137 000	6,1	PCMW 183201.5 B	–
	32	1,5	25	2,25	1	65 500	137 000	5,3	–	PCMW 183201.5 M
20	36	1,5	28	3,25	1	56 000	176 000	7,8	PCMW 203601.5 B	–
	36	1,5	28	3,25	1	85 000	176 000	6,7	–	PCMW 203601.5 M
22	38	1,5	30	3,25	1	60 000	186 000	8,8	PCMW 223801.5 B	–
	38	1,5	30	3,25	1	90 000	186 000	7,7	–	PCMW 223801.5 M
26	44	1,5	35	3,25	1	78 000	245 000	11	PCMW 264401.5 B	–
	44	1,5	35	3,25	1	118 000	245 000	9,4	–	PCMW 264401.5 M
28	48	1,5	38	4,25	1	93 000	290 000	13	PCMW 284801.5 B	–
	48	1,5	38	4,25	1	140 000	290 000	11	–	PCMW 284801.5 M
32	54	1,5	43	4,25	1	116 000	365 000	16	PCMW 325401.5 B	–
	54	1,5	43	4,25	1	176 000	365 000	14	–	PCMW 325401.5 M
38	62	1,5	50	4,25	1	150 000	465 000	21	PCMW 386201.5 B	–
	62	1,5	50	4,25	1	224 000	465 000	18	–	PCMW 386201.5 M
42	66	1,5	54	4,25	1	163 000	510 000	23	PCMW 426601.5 B	–
	66	1,5	54	4,25	1	240 000	510 000	19	–	PCMW 426601.5 M
48	74	2	61	4,25	1,5	200 000	620 000	37	PCMW 487402 B	–
	74	2	61	4,25	1,5	300 000	620 000	34	–	PCMW 487402 M
52	78	2	65	4,25	1,5	208 000	655 000	39	PCMW 527802 B	–
	78	2	65	4,25	1,5	315 000	655 000	36	–	PCMW 527802 M

Composite strip

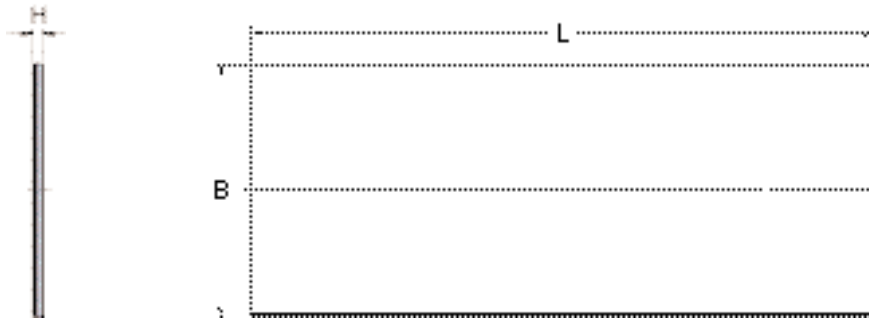

Dimensions			Mass	Designations	
B	L	H		PTFE composite	POM composite
mm			kg	-	
100	500	1,0	0,35	PCMS 1005001.0 B	-
	500	1,0	0,28	-	PCMS 1005001.0 M
100	500	1,5	0,55	PCMS 1005001.5 B	-
	500	1,5	0,46	-	PCMS 1005001.5 M
100	500	2,0	0,75	PCMS 1005002.0 B	-
	500	2,0	0,65	-	PCMS 1005002.0 M
100	500	2,5	0,55	PCMS 1005002.5 B	-
	500	2,5	0,85	-	PCMS 1005002.5 M

Other related products

Maintenance-free FW plain bearings

FW bushings are produced by a winding technique from a self-lubricating composite. The sliding layer consists of strands of high-strength polyester and reinforced PTFE (polytetrafluoroethylene) in an epoxy resin matrix. The shell or backing is made of wound high-strength tensioned glass fibre also in an epoxy resin matrix. The sliding and backing layers are firmly anchored to each other. Both layers are produced

by winding endless strands in a criss-cross pattern.

Modern filament winding technology has made it possible to combine the special mechanical properties of glass fibre with the excellent tribological properties of high-strength thermoplastic and PTFE fibres embedded in epoxy resin to produce a new innovative bearing material. The defined position of the strands in the criss-cross pattern and the intensive binding between the strands and the resin provide very high load carrying capacity and wear resistance.

The maintenance-free FW plain bearings are only available as cylindrical bushings. They are intended for radially loaded bearing arrangements for oscillating, rotational and linear movement, where there is risk of heavy edge loading and/or where chemical resistance under maintenance-free operation is required. They can be used at temperatures between -50 and $+140$ °C.

Assortment

The range of SKF maintenance-free FW bushings currently comprises bushings with bore diameters of 20 to 280 mm.

More information

More information about FW bushings can be found on CD-ROM 4700 "SKF Interactive Engineering Catalogue". Basic technical data are also given in leaflet Dd 7689 "Fibre composite instead of bronze: Maintenance-free FW bushings. The new plain bearing generation."



SKF spherical plain bearings

For arrangements where alignment movements have to be accommodated between two components in relative motion or where tilting movements or oscillations occur at relatively low sliding velocities, normally only spherical plain bearings are suitable. They have an inner ring with a sphered convex outside surface and an outer ring with a correspondingly sphered but concave inside surface. Wherever spherical plain bearings are needed, whether maintenance can be provided or not, SKF spherical plain bearings will meet the bill.

The bearings requiring maintenance have the sliding contact surface combination steel-on-steel. As a rule, bearings with this sliding contact surface combination require regular relubrication. The high wear resistance of

the sliding surfaces makes these bearings especially suitable for arrangements where heavy loads of alternating direction, shock loads or heavy static loads have to be accommodated.

The SKF maintenance-free spherical plain bearings incorporate special sliding layers of advanced materials which have very low friction. They are used for applications where long bearing lives are required without maintenance, or where operating conditions like inadequate or total absence of lubrication do not allow the use of steel-on-steel bearings. SKF maintenance-free bearings are produced with three different sliding contact surface combinations, depending on bearing size and series. These three sliding contact surface combinations are

- steel/sinter bronze composite,
- steel/PTFE fabric, and
- steel/PTFE composite.

Assortment

The comprehensive SKF assortment comprises radial, angular contact and thrust bearings and covers a journal diameter range between 4 and 1 250 mm.

Further information

For detailed information about SKF spherical plain bearings please refer to CD-ROM 4700 "SKF Interactive Engineering Catalogue" or brochure 4407 "SKF spherical plain bearings and rod ends".

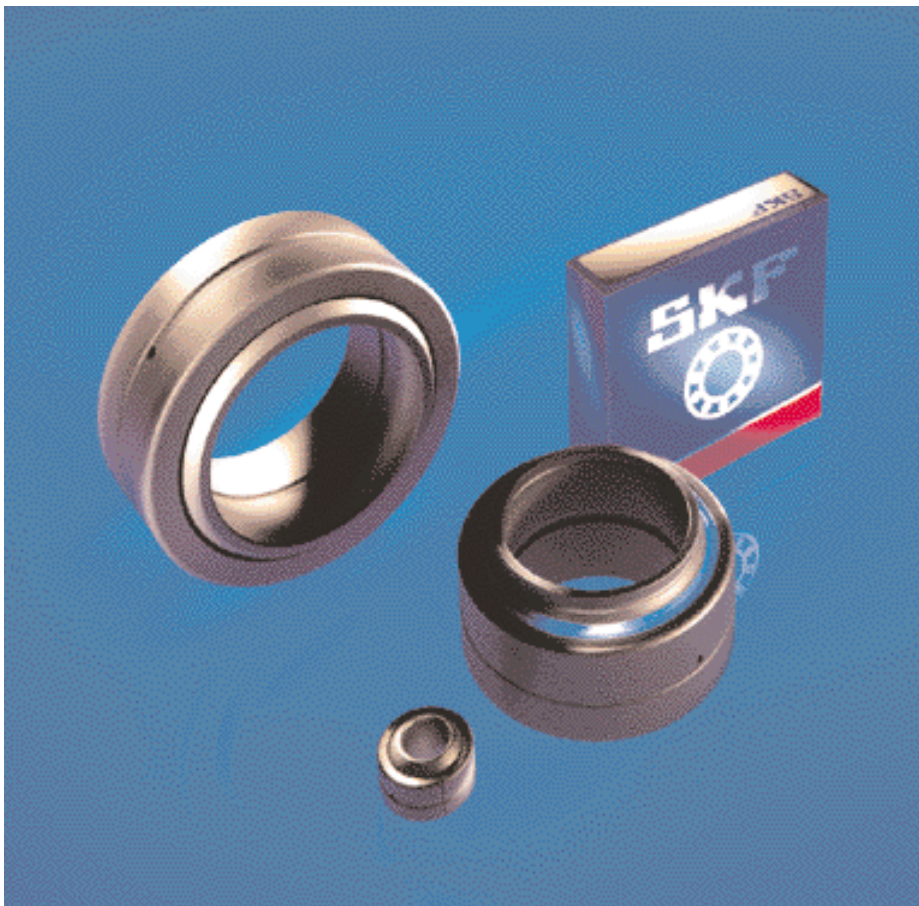

SKF rod ends

Rod ends have been designed for use in construction and control rod linkages, for the end of a piston rod or the base of pneumatic or hydraulic cylinders where tractive and compressive loads have to be transmitted at the same time as alignment movements have to be accommodated. A rod end is basically an eye-shaped head with integral shank (the housing) and a self-aligning bearing. Most SKF rod ends incorporate a standard spherical plain bearing which is held in the housing bore by staking at both sides or by retaining rings. The wide range of SKF rod ends contains products suitable for heavy alternating loads as well as for operation without maintenance.

The SKF rod ends requiring maintenance are available with the sliding contact surface combinations steel-on-steel and steel-on-bronze, the

majority being steel-on-steel rod ends. These rod ends generally require periodic relubrication. The high wear resistance of the sliding surfaces makes steel-on-steel rod ends especially suitable for arrangements where loads of alternating direction or relatively heavy static loads have to be accommodated. Under such operating conditions but where lubricant starvation may be encountered, steel-on-bronze rod ends are recommended.

SKF maintenance-free rod ends are produced with three different sliding contact surface combinations, depending on size and series. These three sliding contact surface combinations are

- steel/sinter bronze composite,
- steel/PTFE fabric, and
- steel/PTFE composite.

The sliding layers of modern materials, which have very low friction, are

the same as those used for SKF maintenance-free spherical plain bearings.

Assortment

The SKF assortment comprises rod ends with female or male thread (left- or right-hand) and also with welding shank. The latter are only available as steel-on-steel rod ends as standard. The assortment covers a pin diameter range between 5 and 200 mm.

Further information

For detailed information about SKF rod ends please refer to CD-ROM 4700 "SKF Interactive Engineering Catalogue" or brochure 4407 "SKF spherical plain bearings and rod ends".



Application examples

The unique properties and excellent performance of dry sliding bearings have led to their use in a variety of industrial, domestic and other applications. They are particularly suitable for conditions where both maintenance and lubrication are either not required or not possible. Examples of typical existing applications for these bearings are as follows.

Automotive

King pins, starter pinions, brake rod linkages, brake shafts, brake shoes, suspensions, window lifts, foot pedals, accelerator linkages, fans, propeller shafts, clutch release levers, steering rods, steering columns, swinging arms, shock absorbers, carburettor butterfly valves etc.

Rail vehicles, railway installations

Automatic doors, level crossing barriers, brakes, pantographs, controllers, load switches, relay boxes, signalling equipment, wagons, points etc.

Aerospace

Brakes, electronic equipment, under-carriages, engines, radar equipment, control devices etc.

Construction industry, conveying equipment

Lifts, excavator drives, excavator arms, excavator control equipment, concrete mixers, fork lift trucks, hydraulic rams, chain tensioning sprockets, crane drives, crane control equipment, crane jibs, mortar carriers, pallet lift trucks, pneumatic lifts, caterpillar graders, escalators, moving pavements, vibrating screens, slides, shuttering cleaning

machines, low loader trailers, winches, conveyors of all kinds etc.

Office machines and equipment

Addressing machines, data processing equipment, tape recorders, swivelling chairs, franking machines, copiers, blueprint copiers, drawing tables, drawing machines etc.

Domestic appliances, hospital equipment

Dental equipment, dishwashers, ironing machines, air conditioning equipment, hospital beds, refrigerators, sewing machines, operating tables, X-ray equipment, vacuum cleaners, washing machines etc.

Machines for agriculture and food-stuff industries

Bottling machines, bakery equipment, timber saws, filtering centrifuges, abattoir and meat processing equipment, hay tedders, potato harvesters, wine-making equipment, loaders, unloaders, combine harvesters, mills, planting machines, root crop harvesters, balers, tractors, tractor seats, automatic packaging equipment, weighing equipment etc.

General engineering

Chamfering machines, bending machines, machines for sheet metal working, briquetting machines, forge machinery, woodworking machines, plastic moulding machines, presses, automatic welding equipment, machine tools, crushing plant etc.

Papermaking and textiles

Cutting machines, printing machines, doubling machines, folding machines, yarn and wool machines, vulcanising machines, carders, button machines, papermaking and paper-treating machinery, sorting devices, spinning machines, stuffers, knitting machines, looms etc.

Pumps, valves

Axial and radial piston pumps, metering pumps, firefighting pumps, compressors, ball cocks, mixer valves, oil burners, pumps for chemicals, regulating valves, submersible pumps, vacuum pumps, spur gear pumps etc.

Electrical equipment

Starting levers for electric motors, contactors, control equipment, switch gear etc.

Automatic devices, tools

Charging and feeding devices, vending machines, pneumatic tools, hydraulic tools etc.

Other uses

Refuse disposal equipment and plant, brake magnets, heat treatment plant, blinds, awnings, smelting furnaces, continuously variable gears, drying plant, steel construction etc.

Linear guide for a car suspension strut piston rod with a PTFE composite bushing

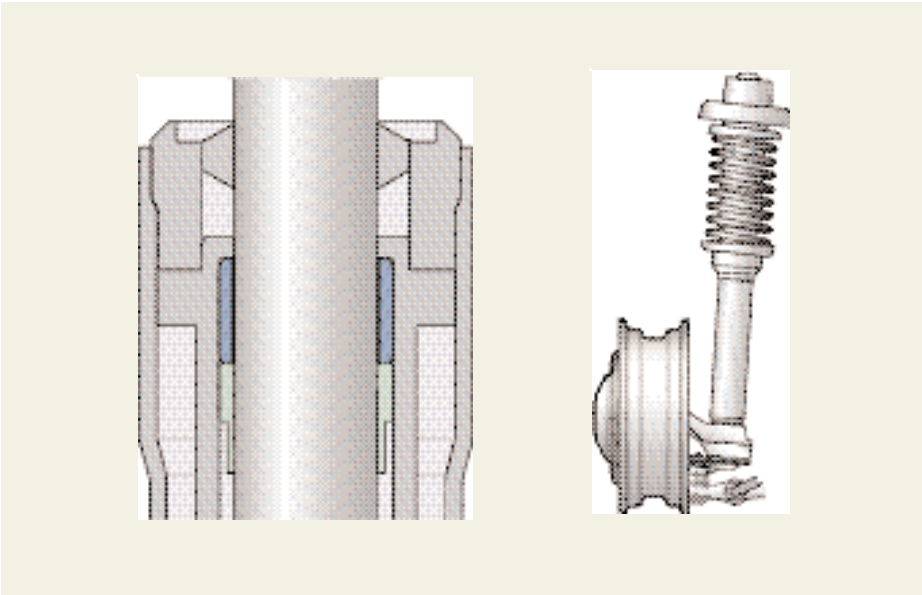

Bearing arrangement for a sunshade (awning) linkage with flanged PTFE composite bushings

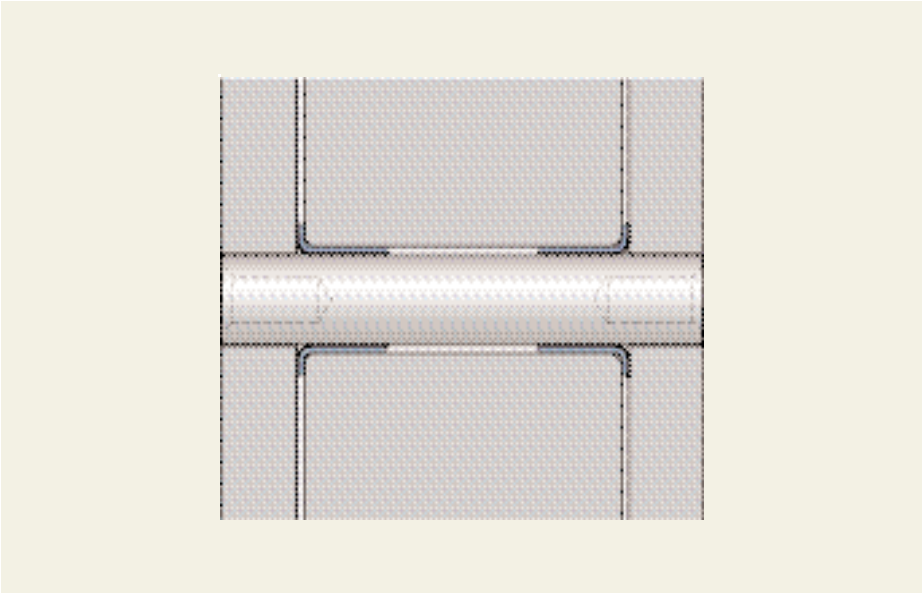

Bearing arrangement for the leaf spring attachment to the upper linkage of a bogie with PTFE composite bushings

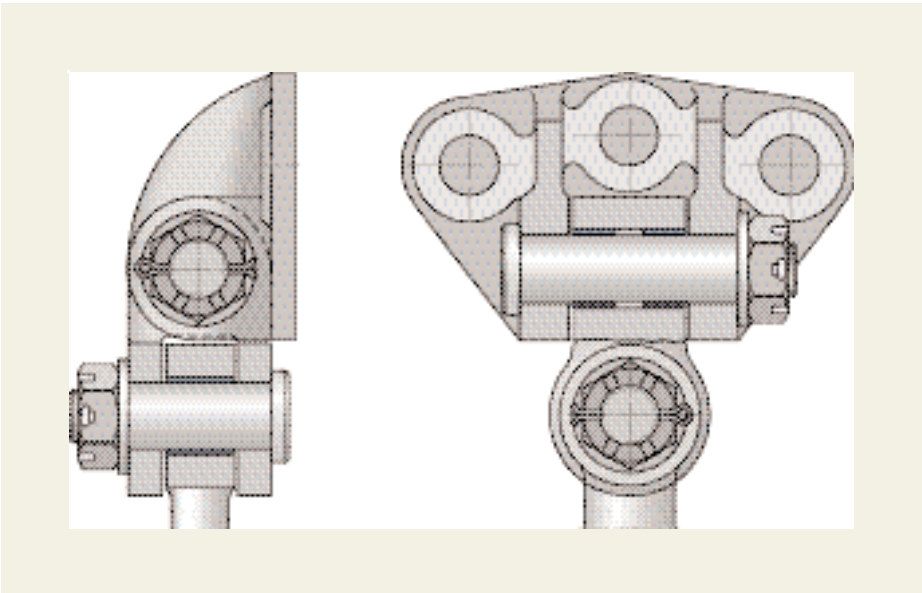

Application examples

Linear guide for a continuously variable governor gear pulley with POM composite bushings

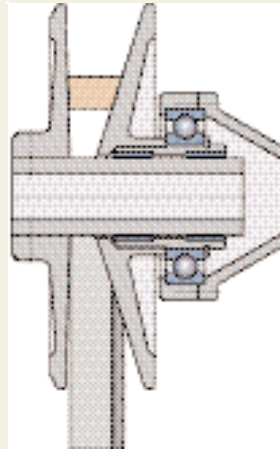

Linear guide for a hydraulic cylinder piston rod with a POM composite bushing

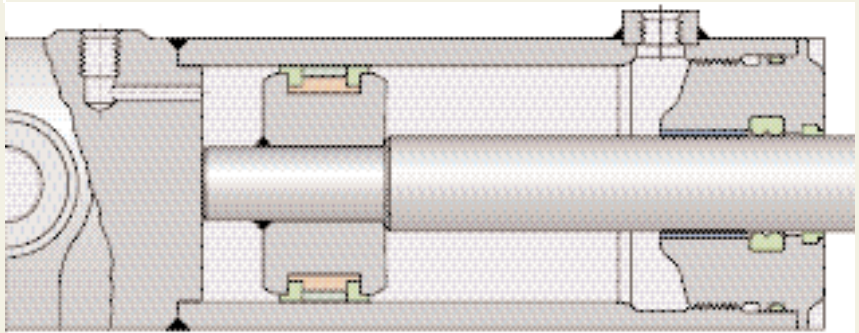

Bearing arrangement for a geared pump with PTFE composite bushings

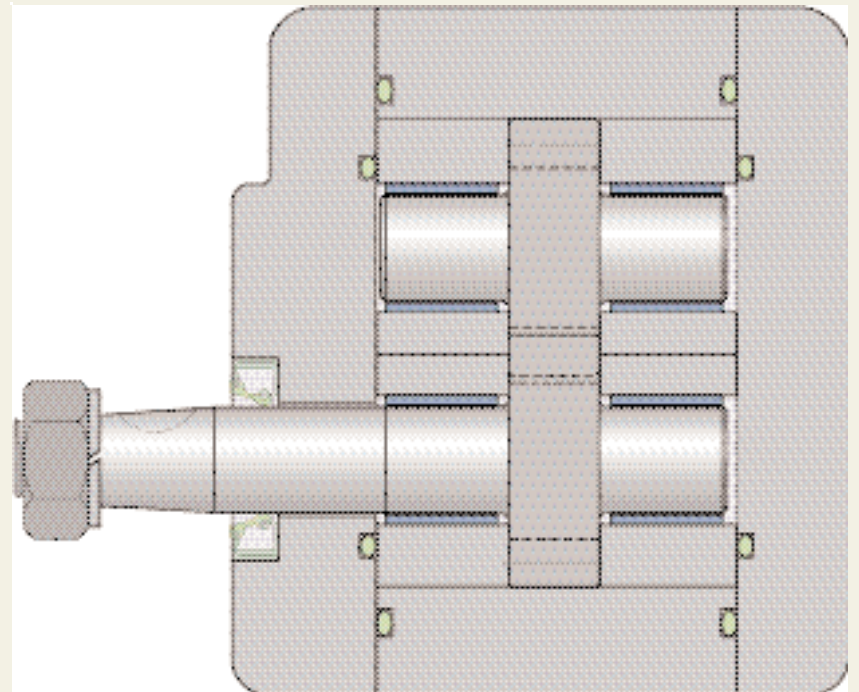

Bearing arrangement for a heavy loader trailer steering gear shift lever with POM composite bushings

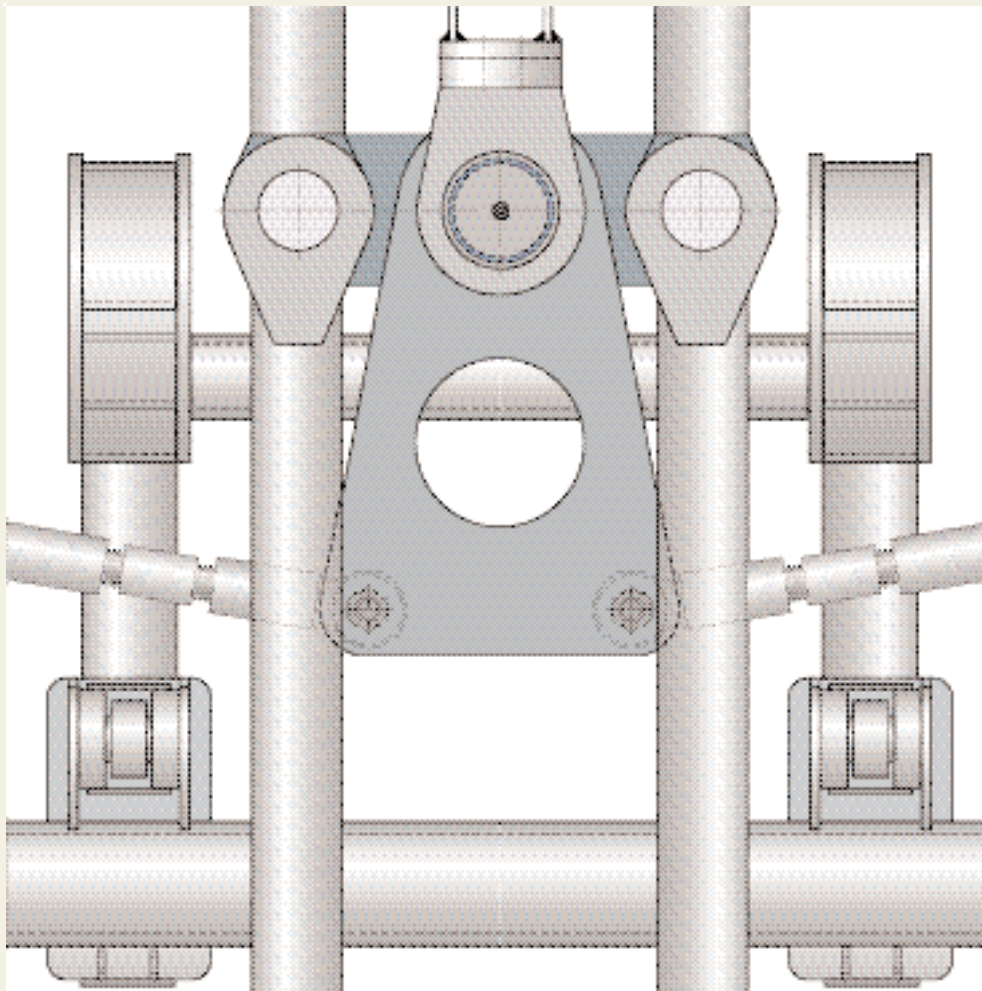
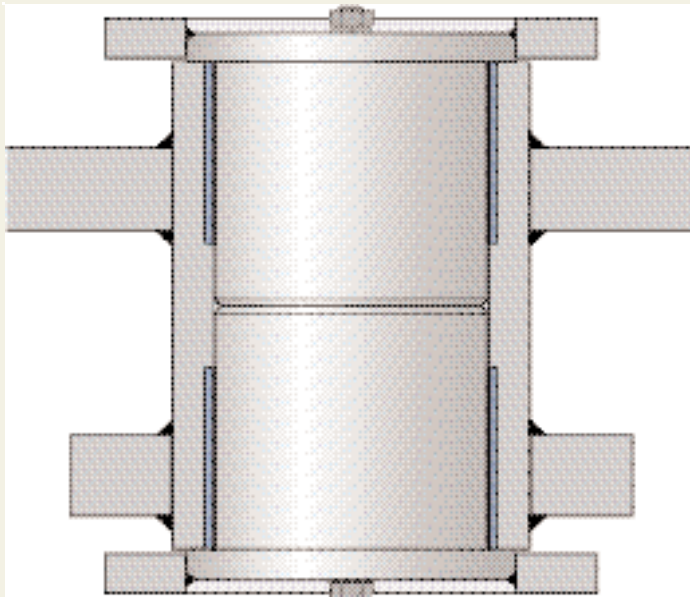

Application examples

Bearing arrangement for a pallet lift truck loading frame coupling rod with POM composite bushings

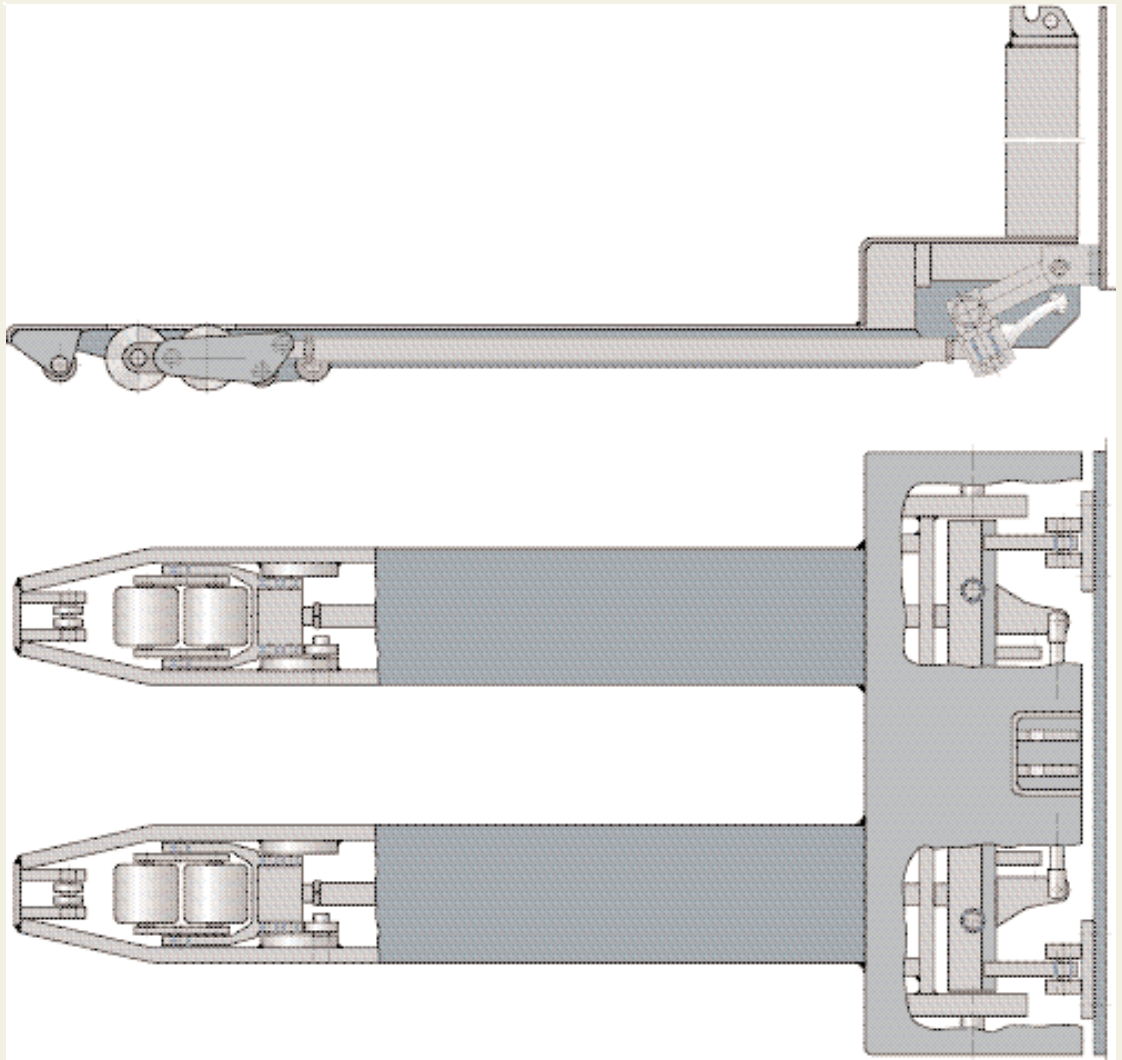

Bearing arrangement for the rotor on an underwater pump with PTFE composite bushings

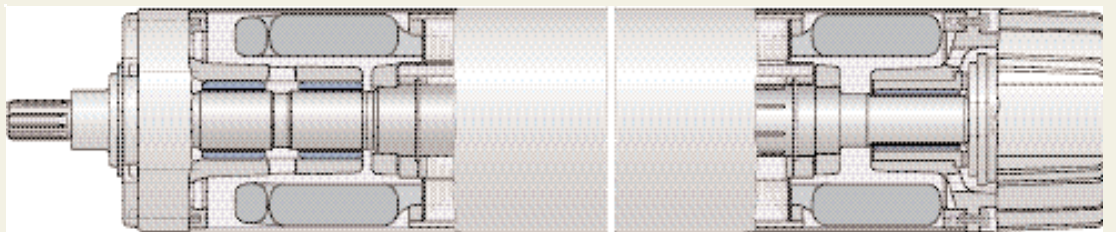

Coupling rod bearing arrangements for a printing press gear lever with PTFE composite bushings

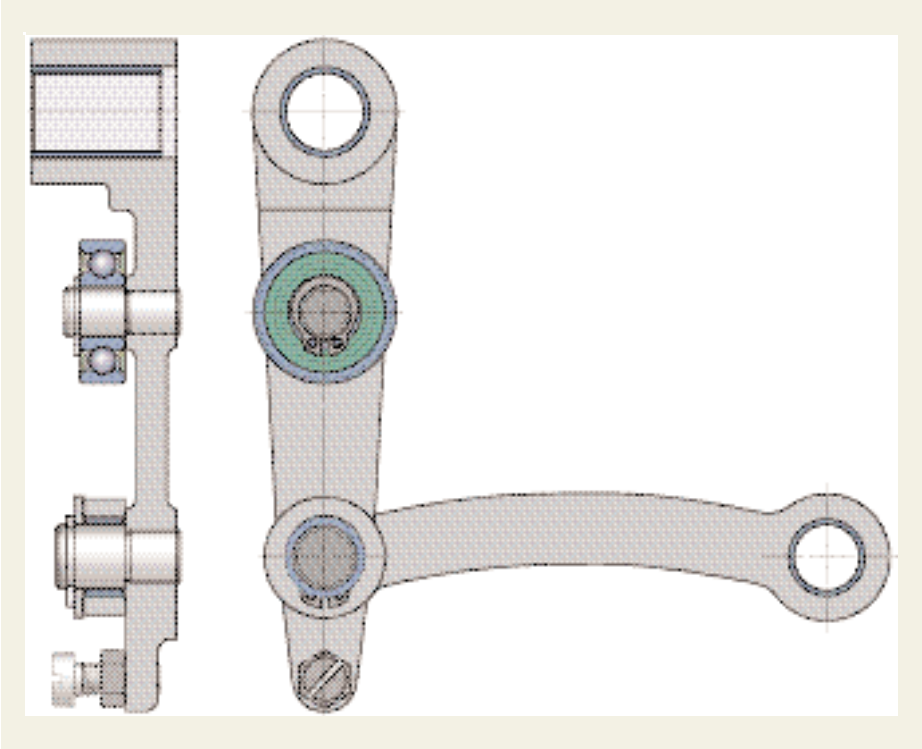

Bearing arrangement for a conveyor roller with a PTFE composite bushing

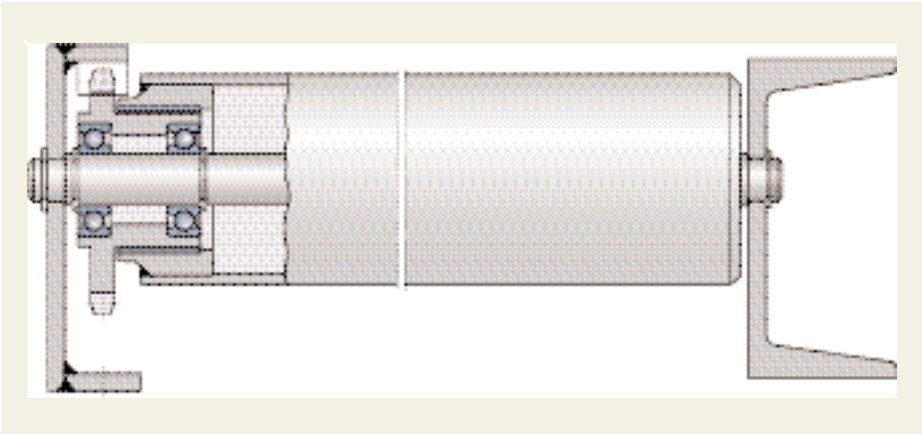

Bearing arrangement for the cutter on debarking equipment with flanged PTFE composite bushings

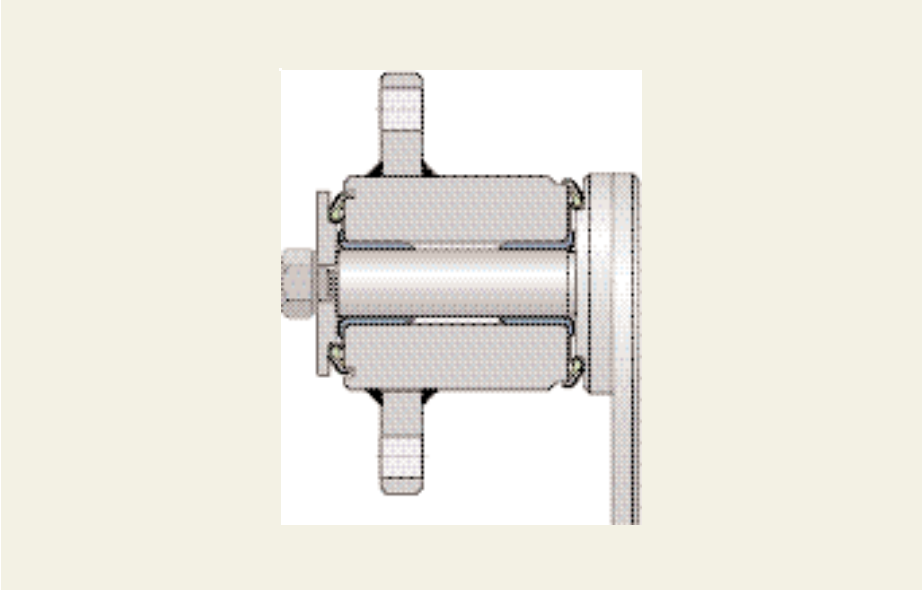

Application examples

Bearing arrangement for the castors on an airline catering trolley with PTFE composite bushings

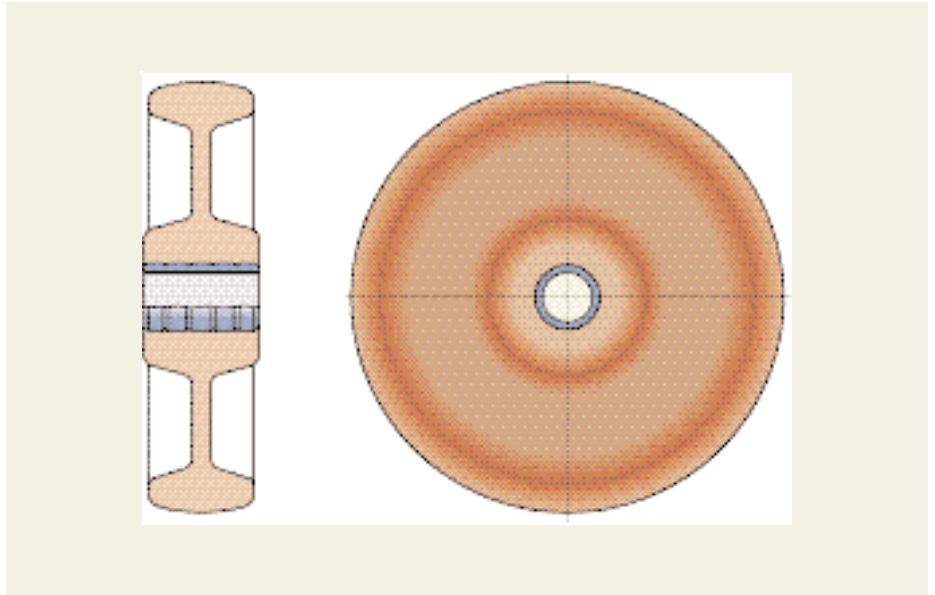

Swivelling device for a wash basin column with POM composite bushings

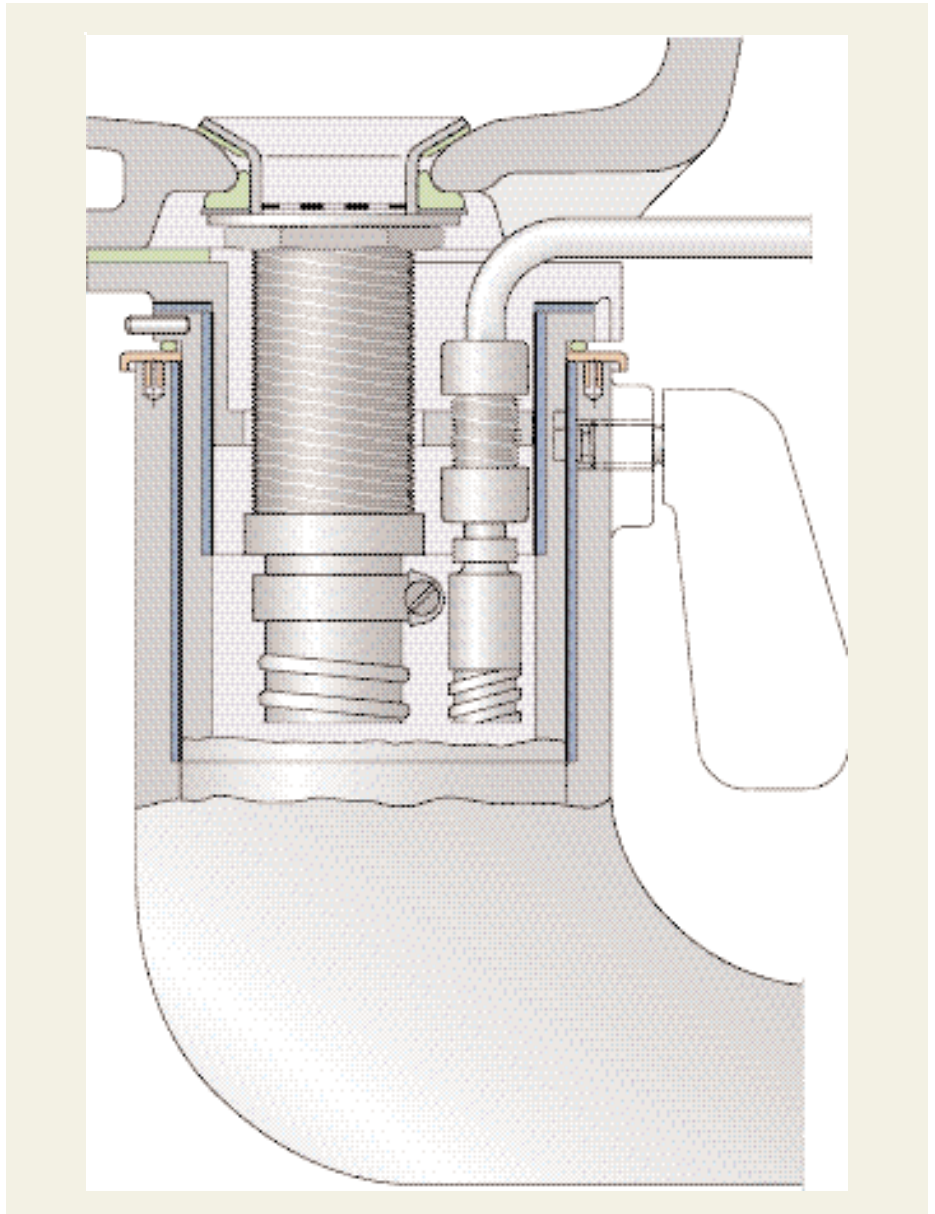

Bearing arrangement for the platform and side rollers of a platform conveyor with POM composite bushings

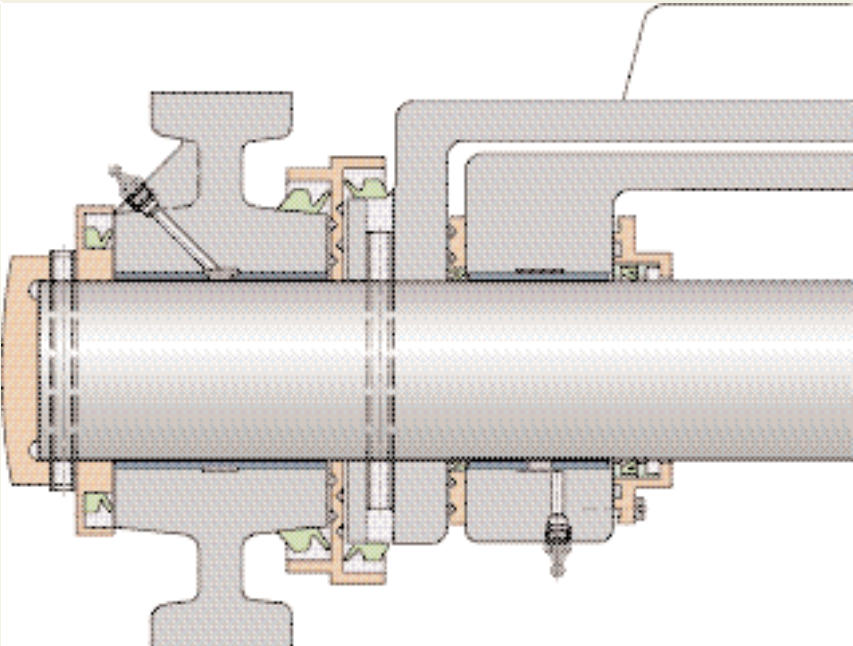

King pin bearing arrangement with POM composite bushings

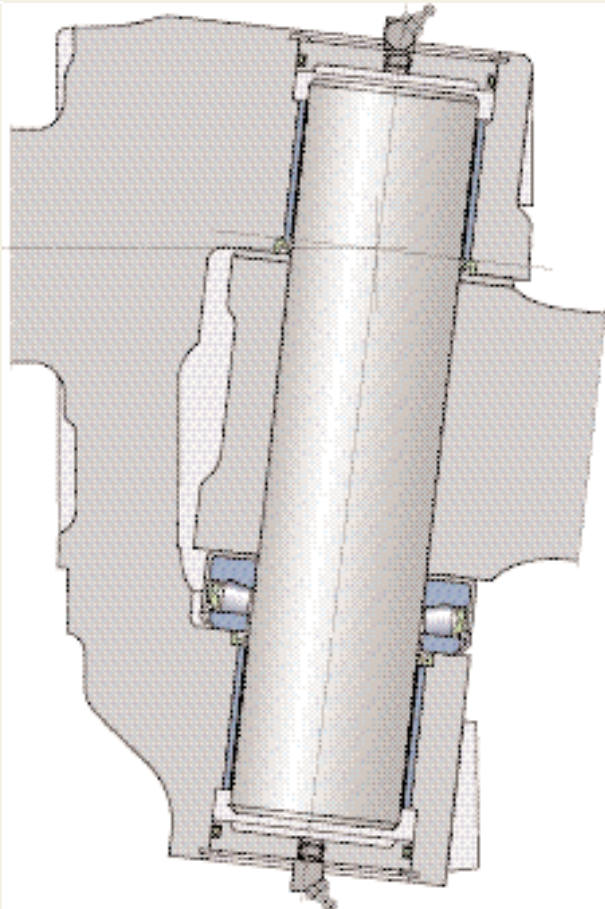

Application examples

*Linear guide for a truck servo steering
with PTFE composite bushings*

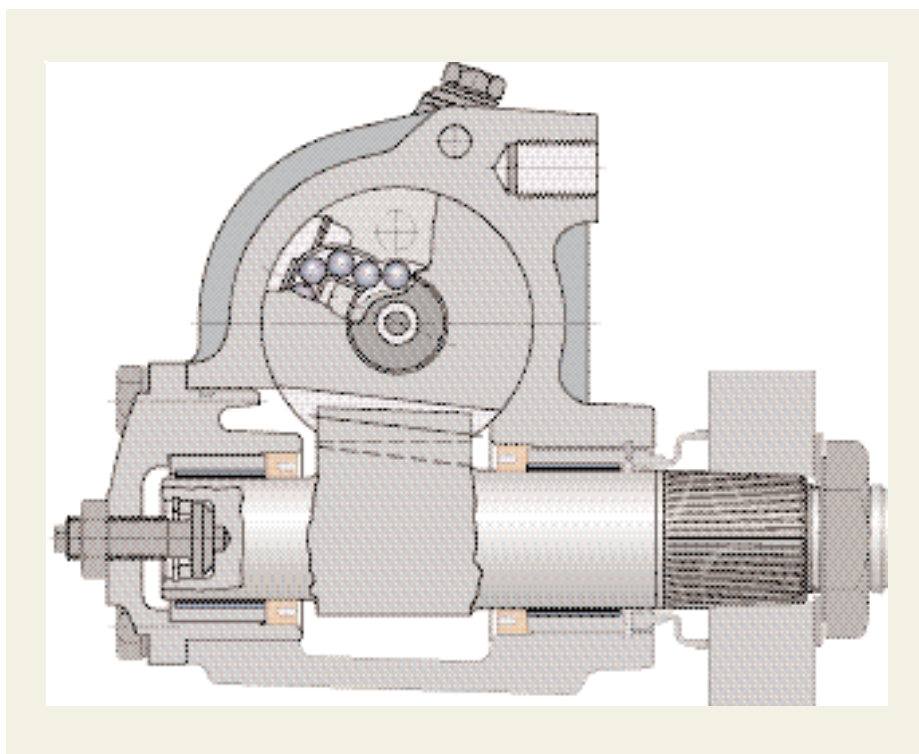

*Bearing arrangement for a lift-off axle
with POM composite bushings and
thrust washers*

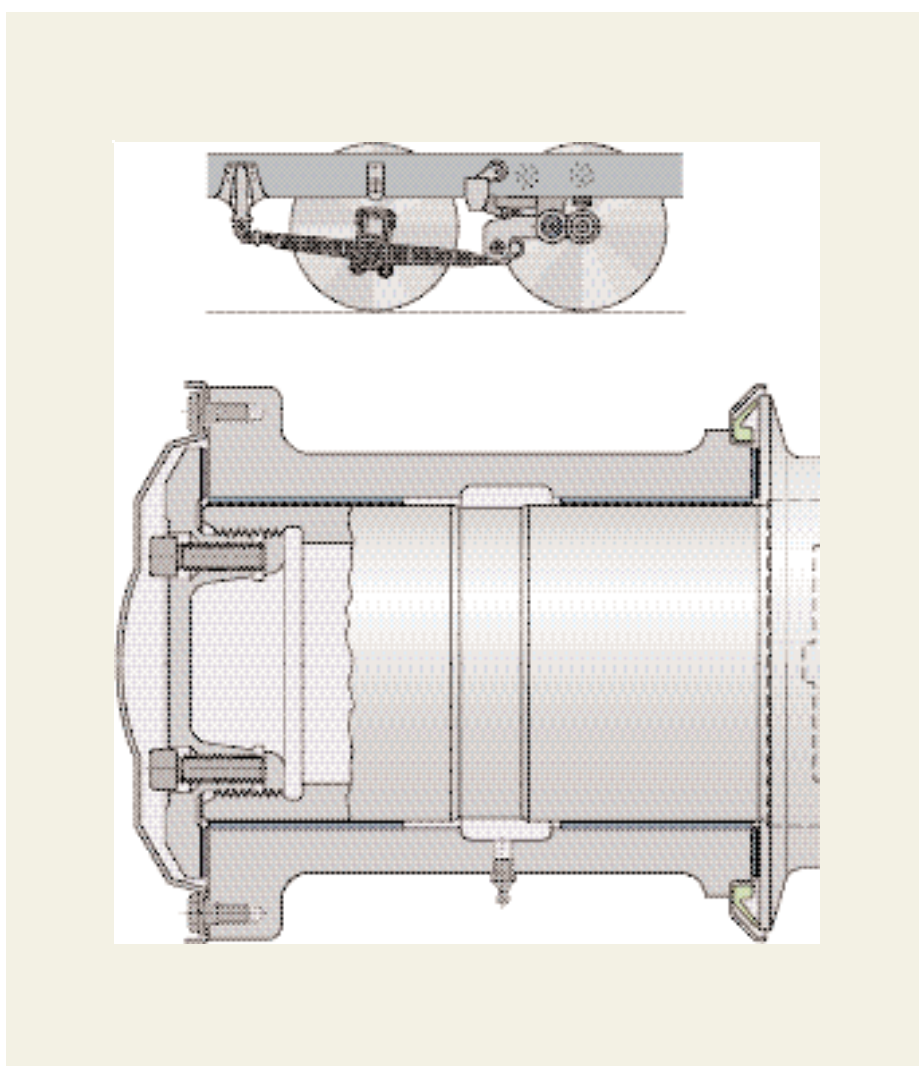

The SKF group - a worldwide corporation

SKF is an international industrial Group operating in some 130 countries and is world leader in bearings.

The company was founded in 1907 following the invention of the self-aligning ball bearing by Sven Wingquist and, after only a few years, SKF began to expand all over the world.

Today, SKF has some 45 000 employees and around 80 manufacturing facilities spread throughout the world. An international sales network includes a large number of sales companies and some 7 000 distributors and retailers. Worldwide availability of SKF products is supported by a comprehensive technical advisory service.

The key to success has been a consistent emphasis on maintaining the highest quality of its products and services. Continuous investment in research and

development has also played a vital role, resulting in many examples of epoch-making innovations.

The business of the Group consists of bearings, seals, special steel and a comprehensive range of other high-tech industrial components. The experience gained in these various fields provides SKF with the essential knowledge and expertise required in order to provide the customers with the most advanced engineering products and efficient service.

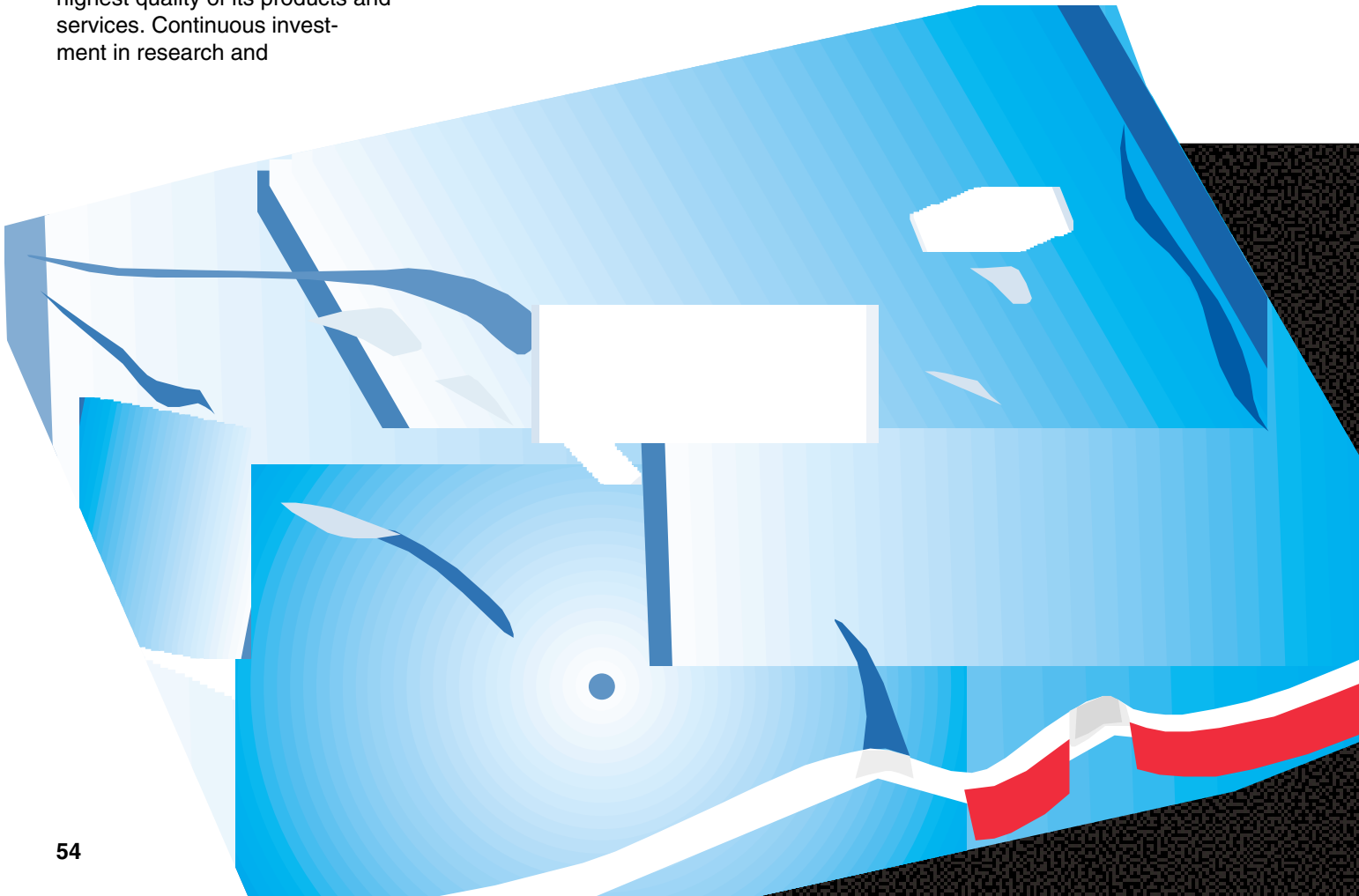



The SKF Group is the first major bearing manufacturer to have been granted approval according to ISO 14001, the international standard for environmental management systems. The certificate is the most comprehensive of its kind and covers more than 60 SKF production units in 17 countries.

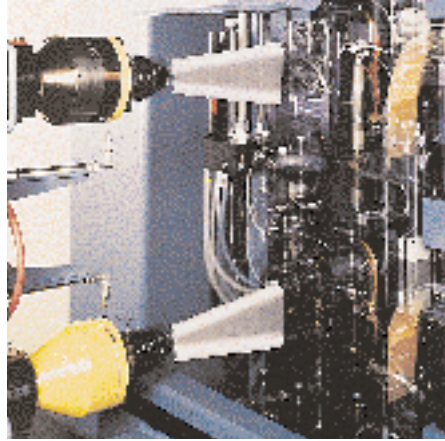

The SKF Engineering & Research Centre is situated just outside Utrecht in The Netherlands. In an area of 17 000 square metres (185 000 sq.ft) some 150 scientists, engineers and support staff are engaged in the further improvement of bearing performance. They are developing technologies aimed at achieving better materials, better designs, better lubricants and better seals – together leading to an even better understanding of the operation of a bearing in its application. This is also where the SKF Life Theory was evolved, enabling the design of bearings which are even more compact and offer even longer operational life.



SKF has developed the Channel concept in factories all over the world. This drastically reduces the lead time from raw material to end product as well as work in progress and finished goods in stock. The concept enables faster and smoother information flow, eliminates bottlenecks and bypasses unnecessary steps in production. The Channel team members have the knowledge and commitment needed to share the responsibility for fulfilling objectives in areas such as quality, delivery time, production flow etc.



SKF manufactures ball bearings, roller bearings and plain bearings. The smallest are just a few millimetres (a fraction of an inch) in diameter, the largest several metres. SKF also manufactures bearing and oil seals which prevent dirt from entering and lubricant from leaking out. SKF's subsidiaries CR and RFT S.p.A. are among the world's largest producers of seals.



© Copyright SKF 1999

The contents of this publication are the copyright of the publisher and may not be reproduced (even extracts) unless permission is granted. Every care has been taken to ensure the accuracy of the information contained in this publication but no liability can be accepted for any loss or damage whether direct, indirect or consequential arising out of the use of the information contained herein.

Publication **4413 E**

Printed in Sweden on environmentally friendly, chlorine-free paper (Multiart Silk) by SG idé & tryck ab.